

*Short Course*

# Towards Circular Economy Compatible Power Electronics

**Johann W. Kolar and Jonas Huber**

Power Electronic Systems Laboratory  
ETH Zurich, Switzerland

June 2, 2024



*Short Course*

# Towards Circular Economy Compatible Power Electronics

**Johann W. Kolar, Jonas Huber, Luc Imperiali, and David Menzi**

Power Electronic Systems Laboratory  
ETH Zurich, Switzerland

June 2, 2024





## Outline

- Decarbonization
- The Elephant in the Room
- **Multi-Objective Optimization**
- Circular Economy Compatibility

Acknowledgment:  
Franz Musil, Fronius International GmbH

# The U.N. SUSTAINABLE DEVELOPMENT GOALS



Source: <https://www.un.org/sustainabledevelopment>

- #7 – “Affordable and clean energy” / #12 – “Responsible consumption and production” / ...

# The Challenge

## ■ Fossil fuels facilitate rapid economic growth and development

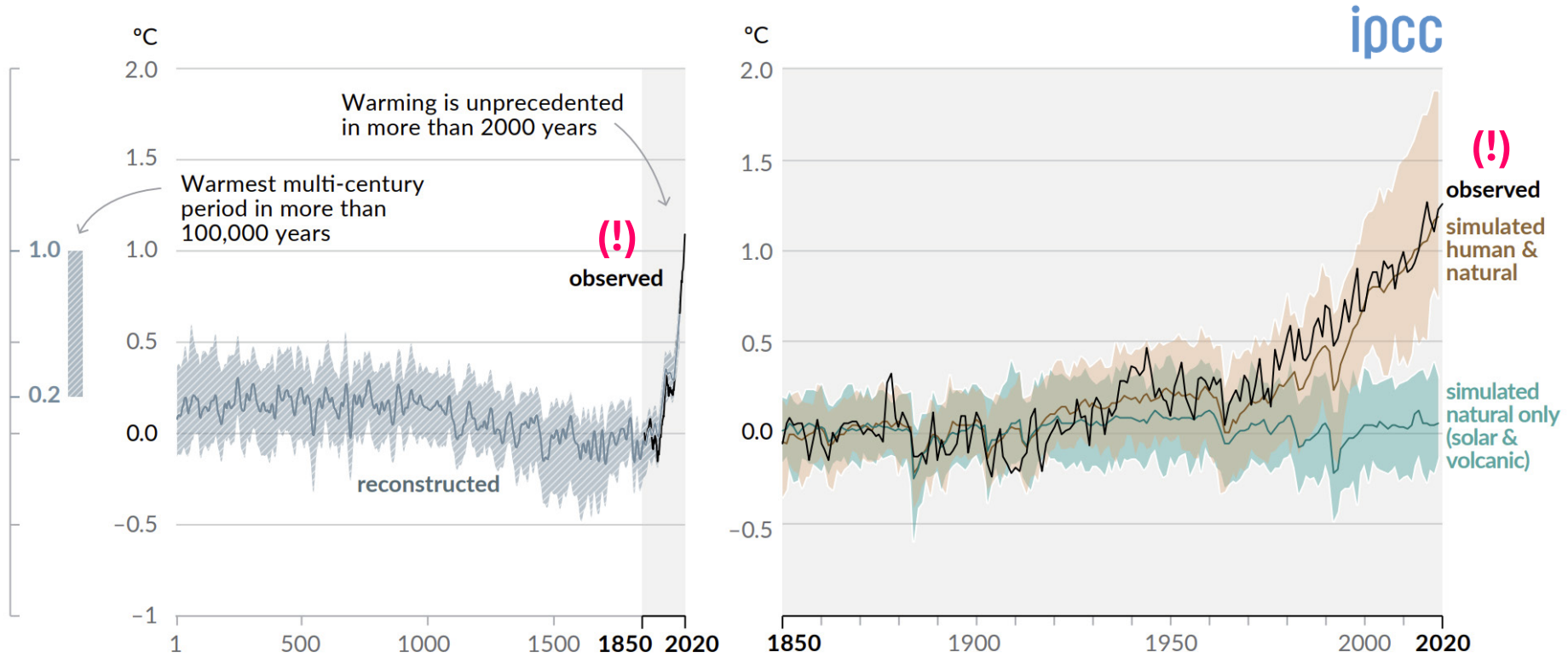

## ■ Anthropogenic greenhouse gas emissions cause climate change / global warming

# Decarbonization / Defossilization

- +2 °C target by 2100: Globally, **30% of oil, 50% of gas, and > 80% of coal reserves must remain unused (!)**
- Ambitious pathway to “net-zero CO<sub>2</sub> emissions by 2050” → Temperature overshoot!

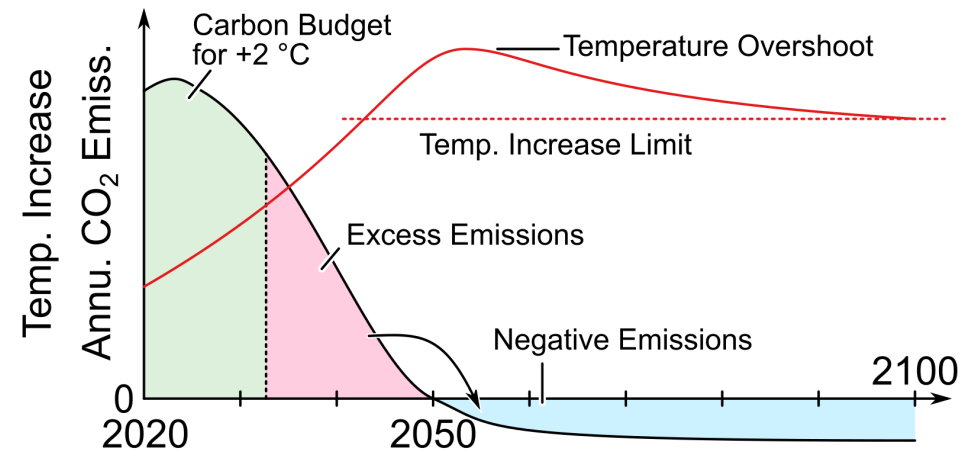
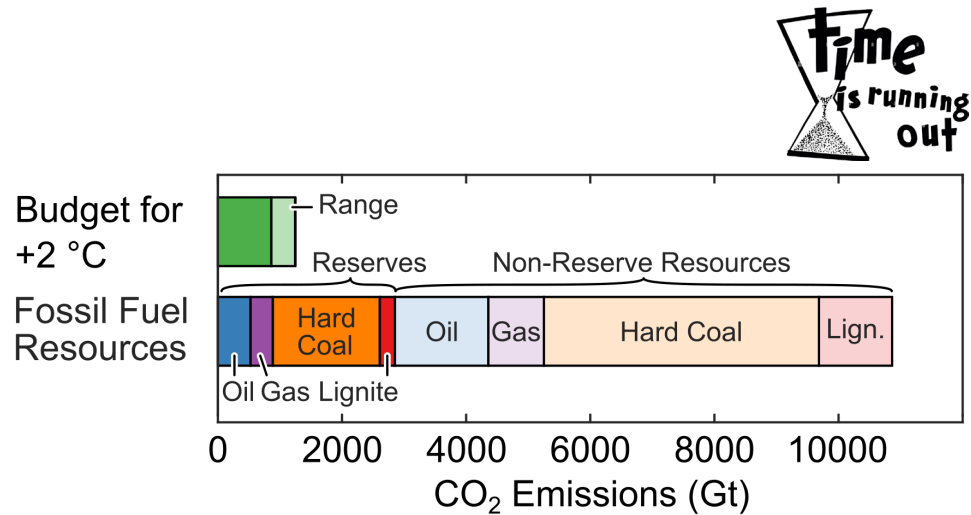

- Human history: **Transition from lower to higher energy density fuel** — Wood → Coal → Oil & Gas
- Challenge of stepping back from oil & gas quickly / **Can't wait for disruptive technologies / panacea!**

# The Opportunity

(2009) 16 TW-yr  $\rightarrow$  16 Tw-yr per year  $\leftarrow$  27 TW-yr (2050)

Renewable energy resources per year

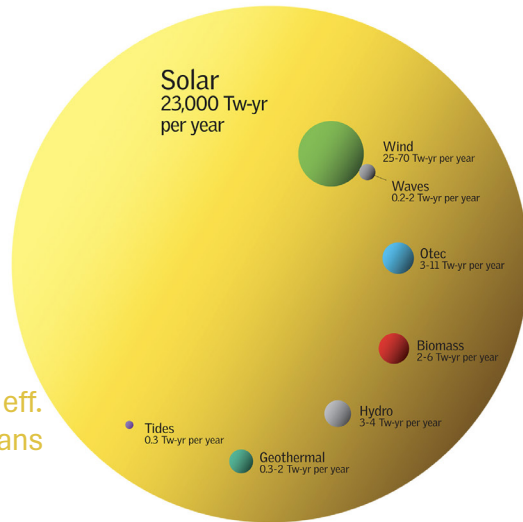

100% convers. eff.  
Excl. oceans

**Note:** Graphical representation assumes spheres, not circles

Primary consumption:  
16 TWyr  $\rightarrow$  27 TWyr  
Final consumption:  
11 TWyr  $\rightarrow$  15 TWyr

Fossil energy resources - total reserve left on earth

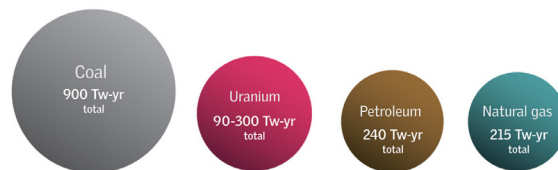

Source: R. Perez et al., IEA SHC Program Solar Update (2009)

## Global distribution of solar & wind resources

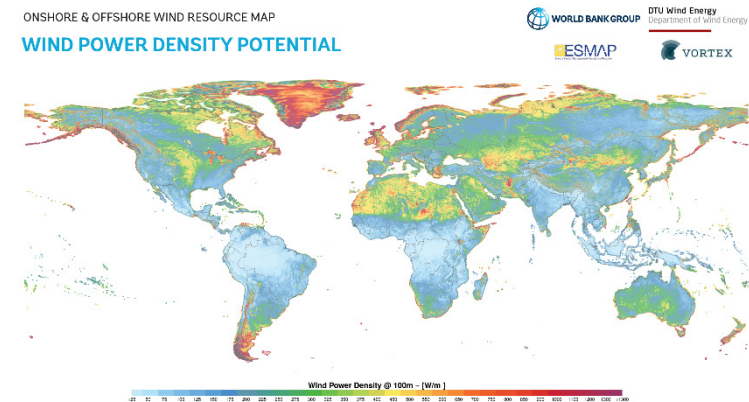
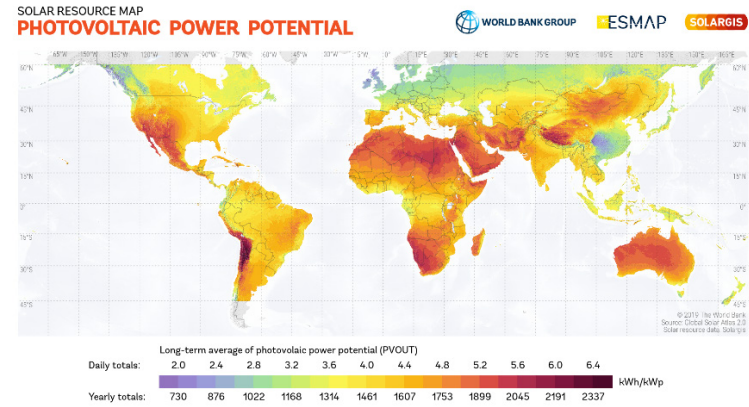

# The Approach

- Outlook of global cumulative installations until 2050
- In 2050 deployment of **370 GW/yr (PV)** and **200 GW/yr (onshore wind)** incl. replacements

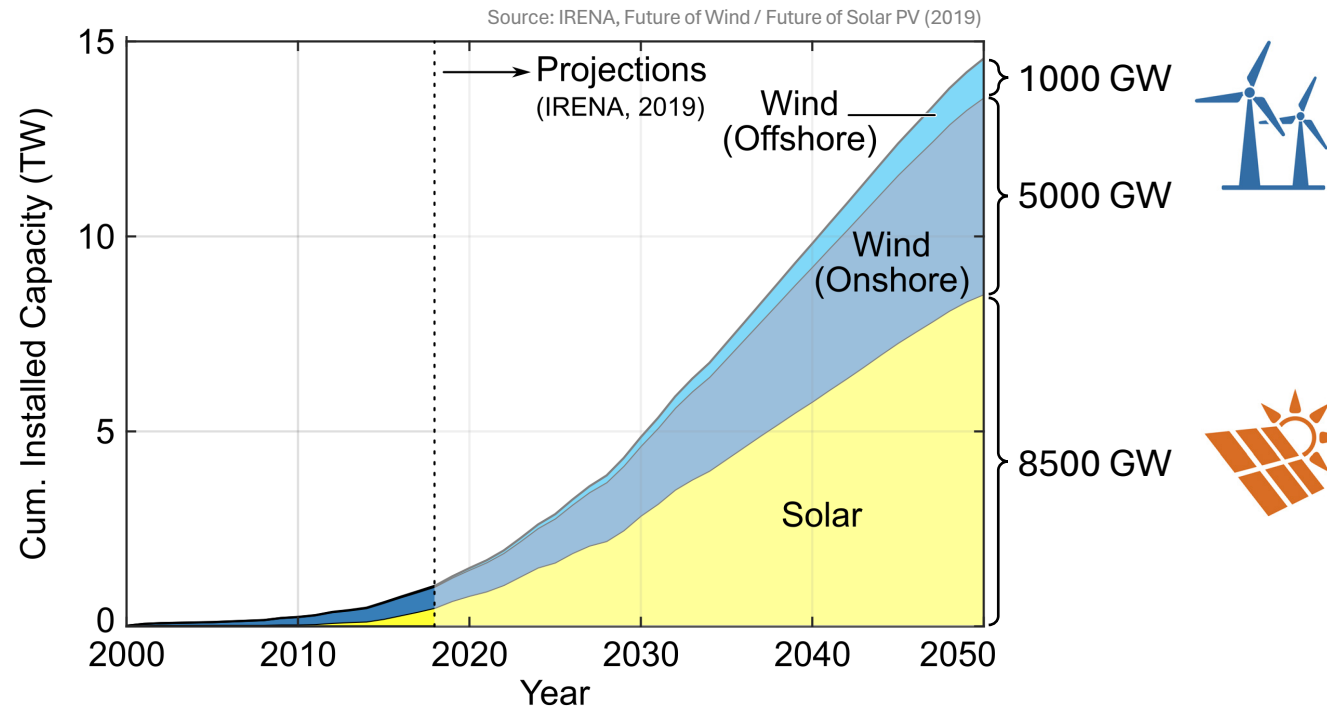

- Dominant share of electric energy — **Power electronics as key enabling technology (!)**



## Remark: Cost of the Clean Energy Transition

- Total **annual spending** for net-zero until 2050: **3.5 TUSD** ( $3.5 \cdot 10^{12}$  USD) / Total 110 TUSD until 2050

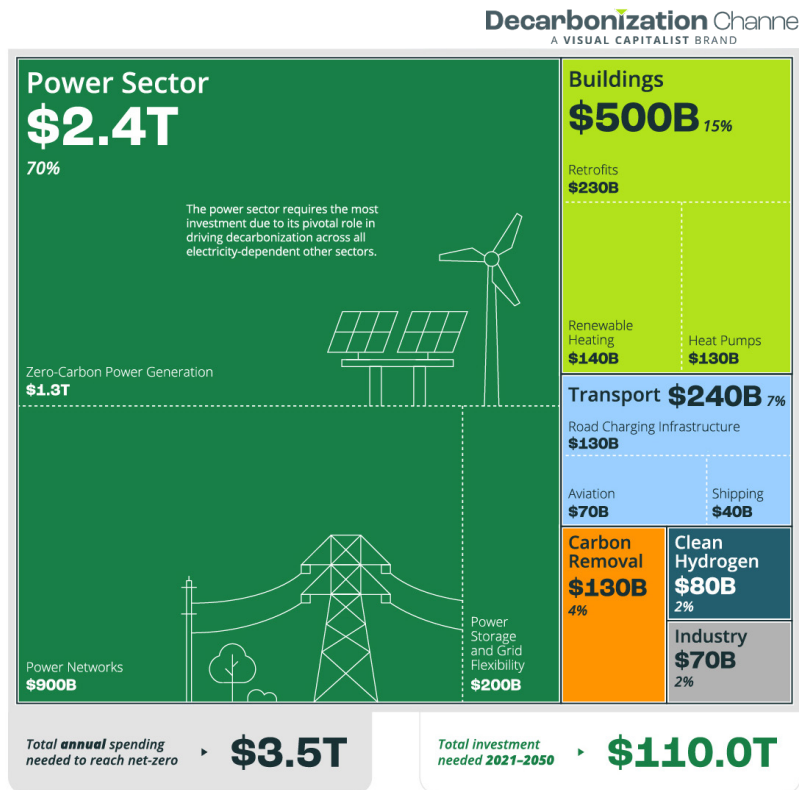

- **Perspectives:**
  - 3.5 TUSD are 12% of the U.S. GDP (2024) or **3% of the world GDP**
  - World defense expenditures 2023 were 2.4 TUSD

# The in the Room

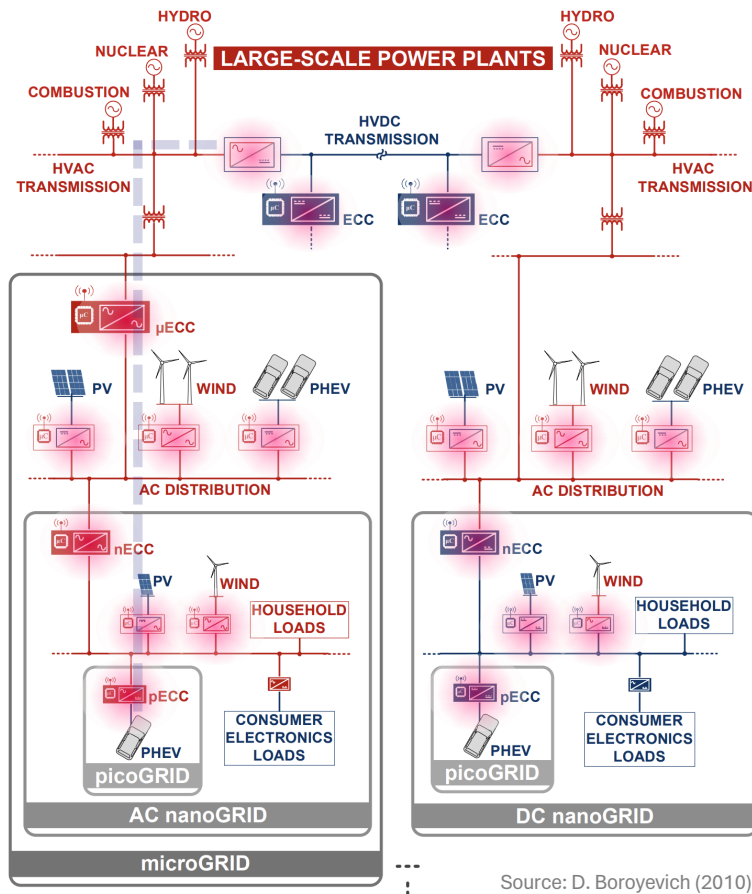

- 25'000 GW installed renewable generation in 2050
- 15'000 GWh installed battery storage
- 4 x power electronic conversion btw. generation & load
- 100'000 GW of installed converter power
- 20 years of useful life

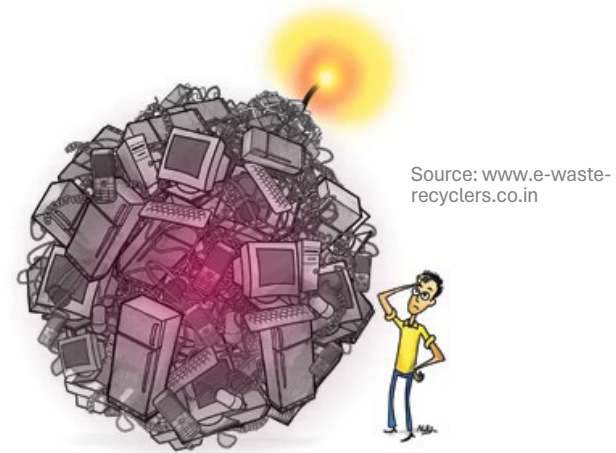

- 5'000 GW<sub>eq</sub> = 5'000'000'000 kW<sub>eq</sub> of e-waste per year (!)
- 10'000'000'000 \$ of potential value

# Growth of Global E-Waste (1)

- Growing global e-waste streams / < 20% recycling!
- 120'000'000 tons of global e-waste in 2050

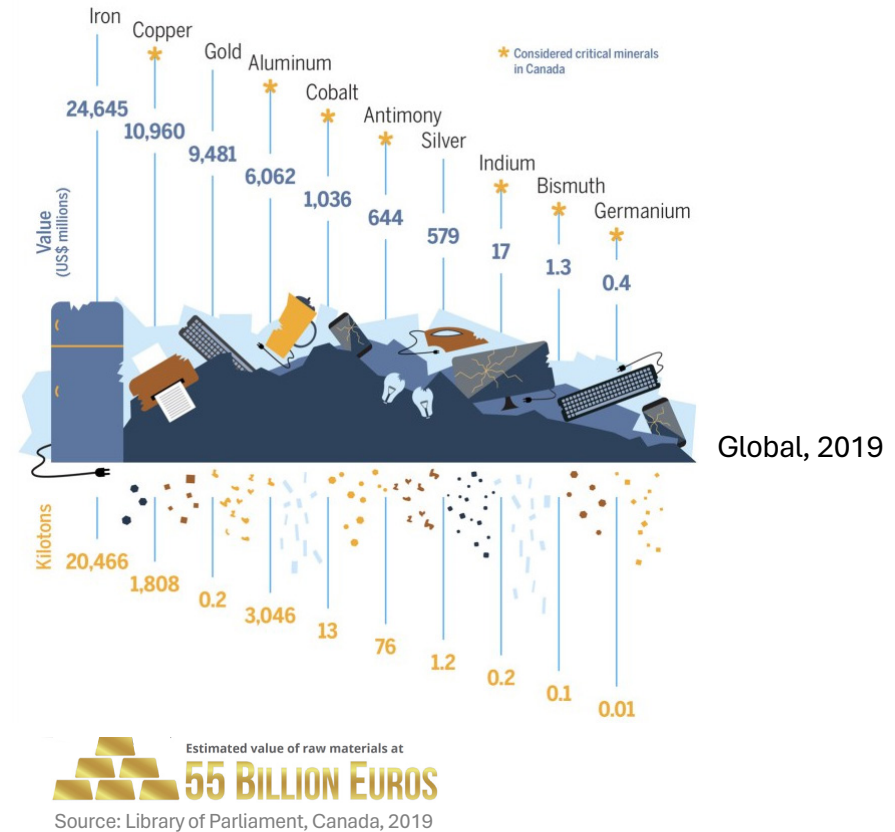
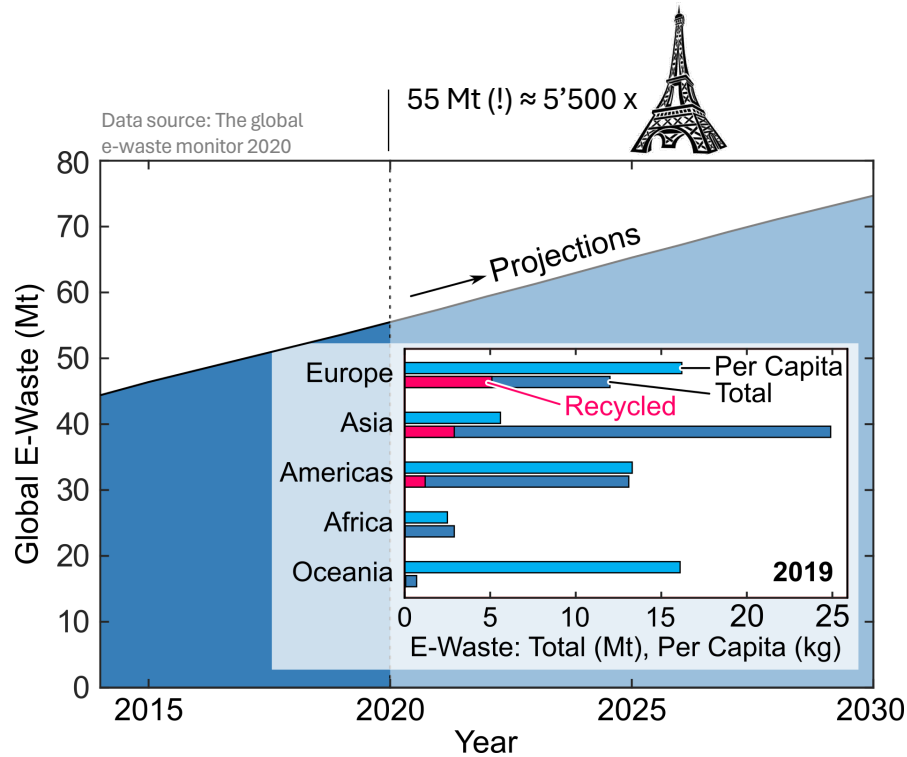

- E-waste represents an “urban mine” with great economic potential

## Growth of Global E-Waste (2)

- Growing global e-waste streams → 120'000'000 tons of global e-waste in 2050
- Increasingly complex constructions → Little repair or recycling

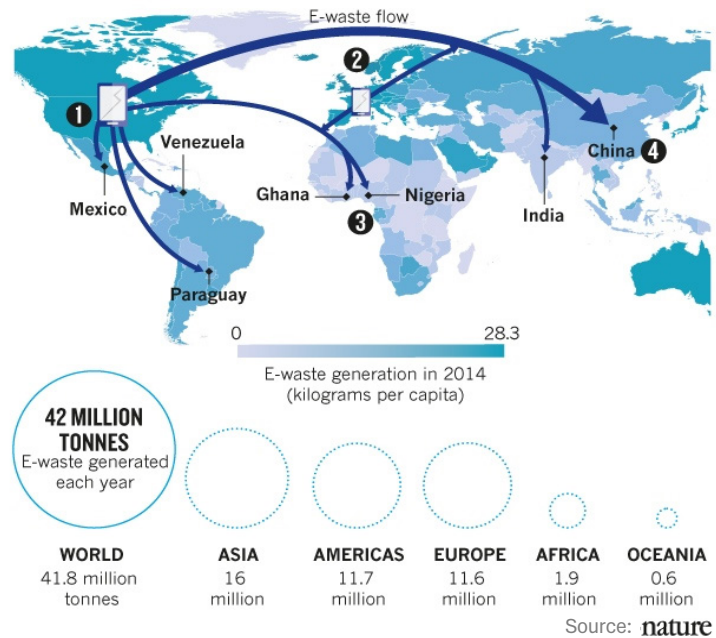

Source: Green IT Solution



- Growing global e-waste streams → Regulations mandatory (!)

# Remark: Critical Minerals

## ■ Production of selected minerals critical for the clean energy transition

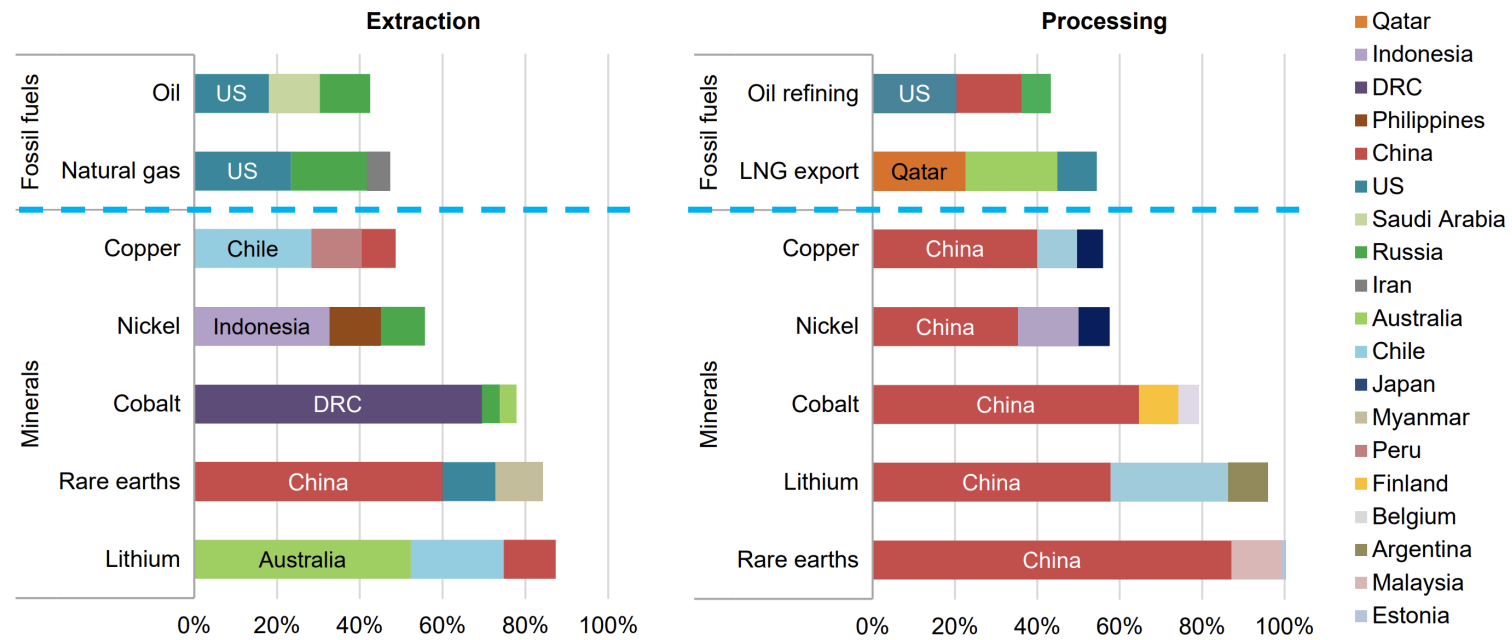

Source: IEA / The Role of Critical Minerals in Clean Energy Transitions (2021)

## ■ Extraction & processing more geographically concentrated than for oil & gas (!)

# The Paradigm Shift

## ■ Linear Economy

- Take – make – dispose

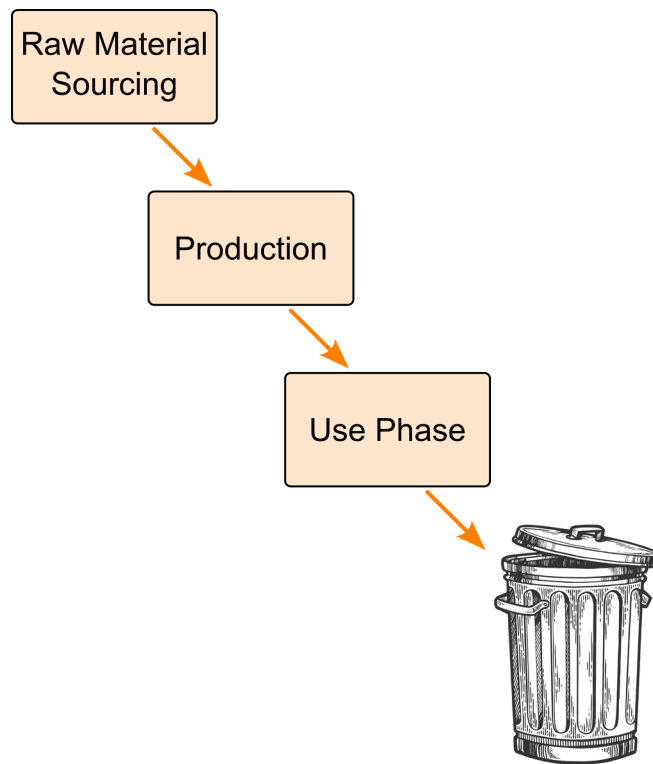

## ■ Circular Economy

- Perpetual flow of resources

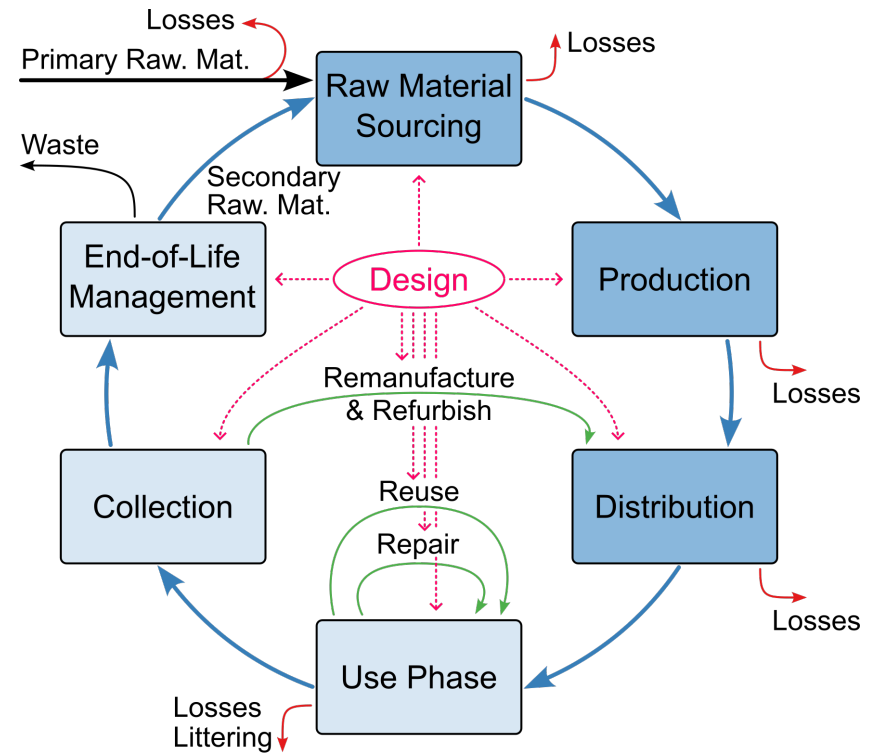

- Resources returned into the product cycle at end of life

## Remark: Policymaking / Regulations / Standardization



### ■ European Green Deal

- Circular Economy Action Plan
- Net-Zero Industry Act
- Critical Raw Materials Act
- Environmental Footprint Methods
- Right to Repair
- Ecodesign for Sustainable Products Regulation
- ...



### ■ Standardization (Examples)

- ISO 14040/14044 Life-cycle assessment
- ISO 14067 Carbon footprint of products
- ISO 4555x Ecodesign and material efficiency
- IEC 62430 **Environmentally conscious design** for el. & electron. products
- IEC 61800-9-1/2 Ecodesign for drive systems
- ...



# Complexity Challenge

- Technological innovation — **Increasing level of complexity & diversity** of modern products
- Exponentially accelerating technological advancement (R. Kurzweil)

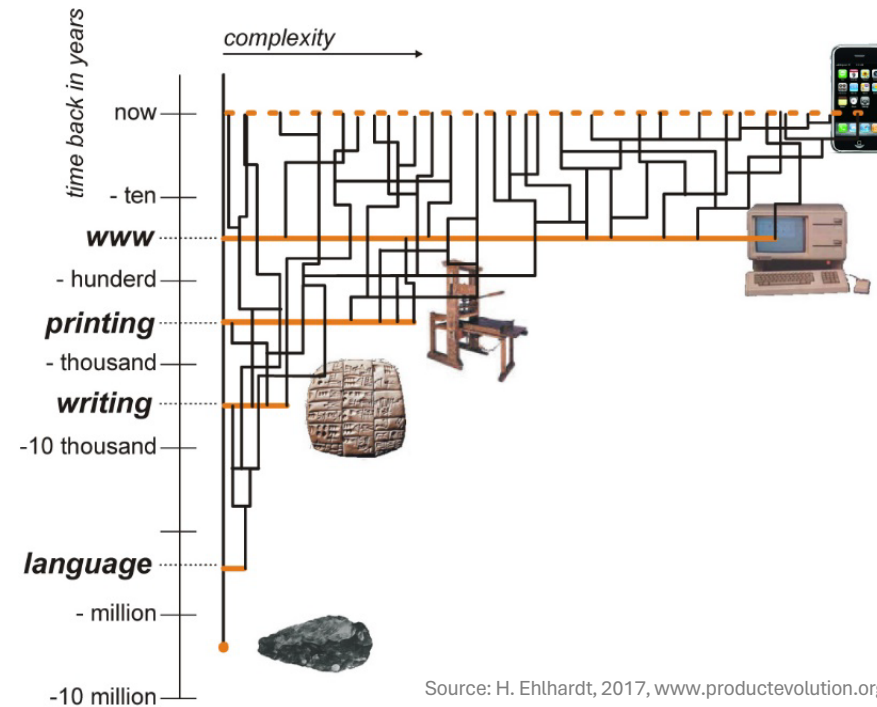

- **Ultra-compact systems / functional integration** — **Major obstacle for material separation!?**



# Design for Repairability & Circularity

- **Eco-design** — Reduce environmental impact of products, incl. life-cycle energy consumption
- **Re-pair / Re-use / Re-cycle** / disassembly / sorting & max. material recovery, etc. considered
- EU eco-design directive (!)

Source:  DLR

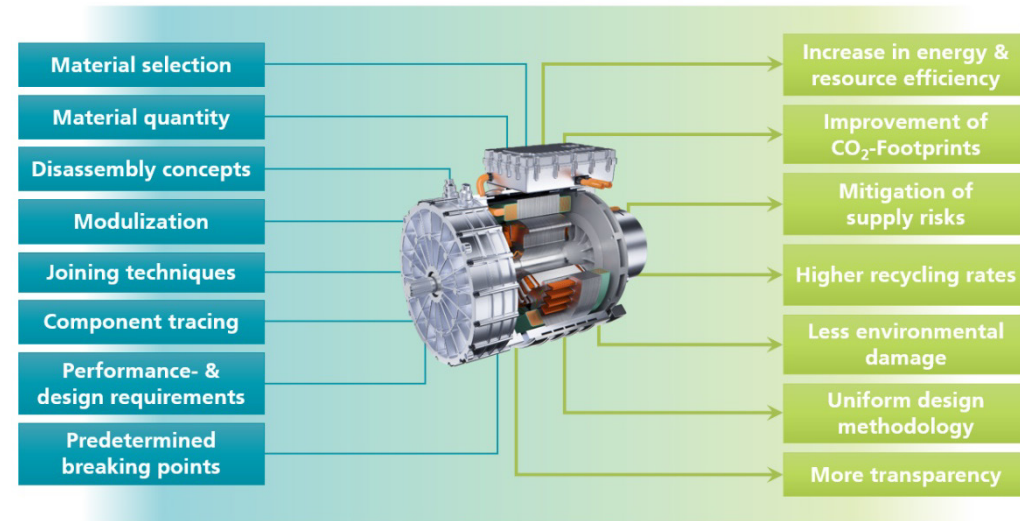

- **FAIRPHONE** — Modular design / man. replaceable parts / 100% recycl. of sold products / fairtrade materials
- **“80% of environmental impact of products are locked-in at the design stage”** — J. Thackara, *In the bubble: Designing in a complex world*. Cambridge, MA, USA: The MIT Press, 2006.

# LCA: Life Cycle Assessment (1)

- Quantification / benchmarking of eco-design & circular economy approaches

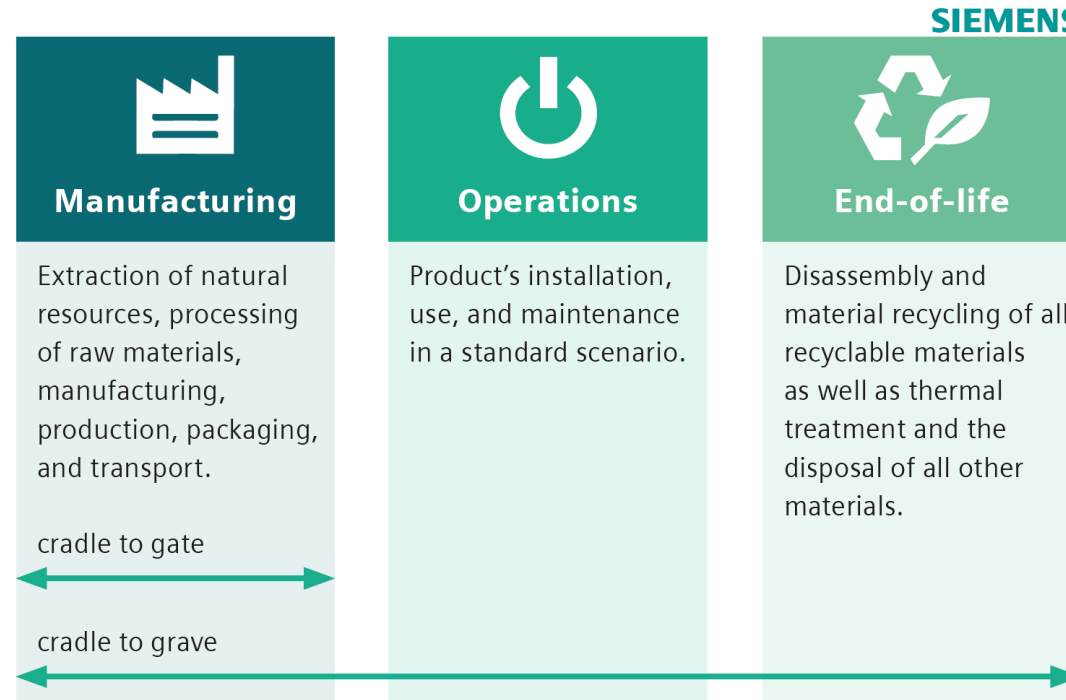

- Scope of LCA can include

- All life-cycle phases (**cradle to grave**) or
- Individual life-cycle phases (**cradle to gate** or gate to gate)

# LCA: Life Cycle Assessment (2)

- Quantification / benchmarking of eco-design & circular economy approaches

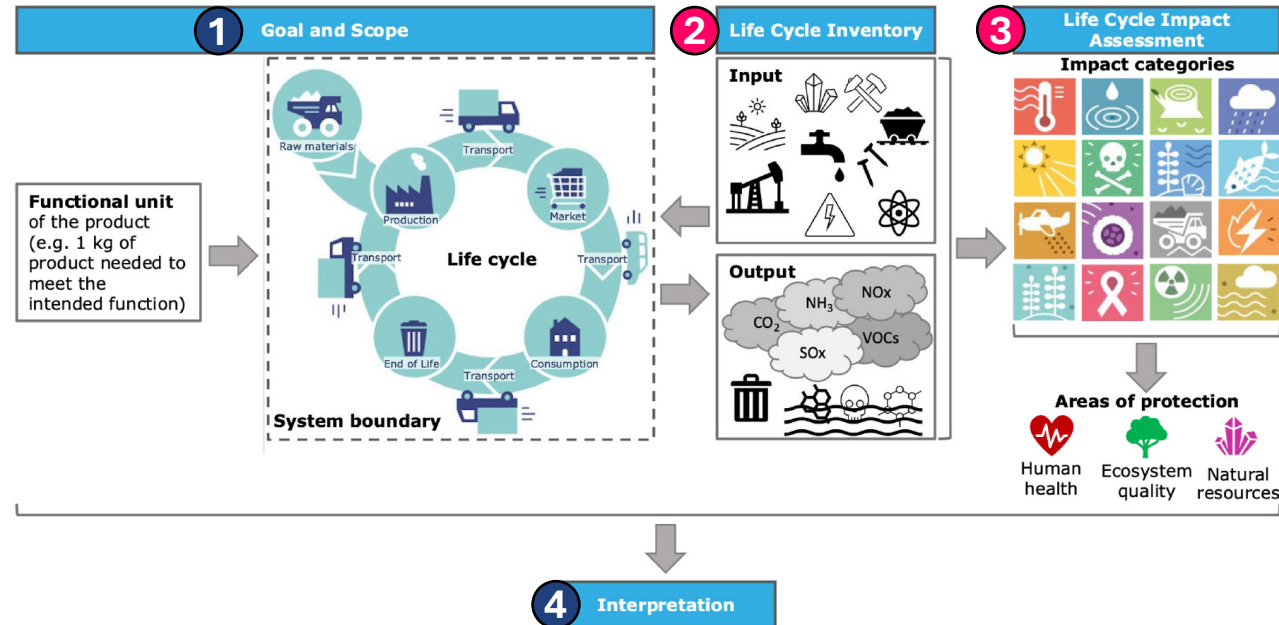

**2 LCI – Life Cycle Inventory**  
 Compilation & quantification of inputs and outputs for a product throughout its life cycle

**3 LCIA – Life Cycle Impact Assessment**  
 Assignment of LCI results to (environmental) impact categories / Aggregation involves weighting factors & value choices

# LCA Example: Carbon Footprint of a 150-kW PV Inverter

- **Production phase** / embodied carbon footprint of **903 kg CO<sub>2</sub>eq** (15...20% of life-cycle carbon footprint)
- **Use phase** contributes **>80%** to life-cycle carbon footprint (conversion losses & standby/night consumption)



**Embodied Carbon Footprint**

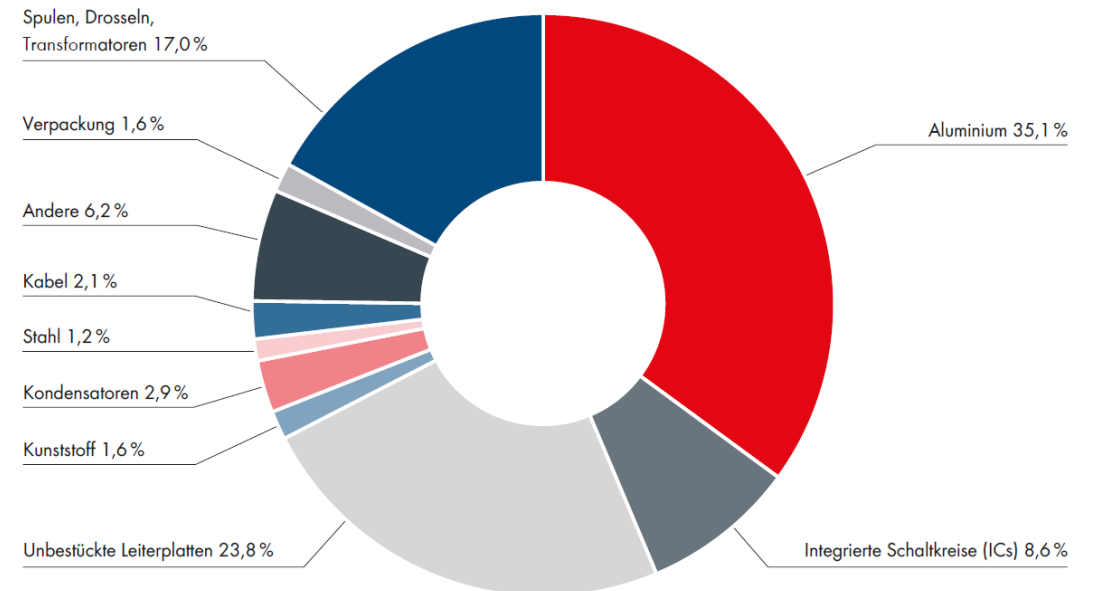

- **150 kW** rated power for typ. 225 kW<sub>p</sub> PV system

# LCA Example: Carbon Footprint of a 150-kW PV Inverter

- **Production phase / embodied carbon footprint of 903 kg CO<sub>2</sub>eq** (15...20% of life-cycle carbon footprint)
- **Use phase contributes >80% to life-cycle carbon footprint** (conversion losses & standby/night consumption)

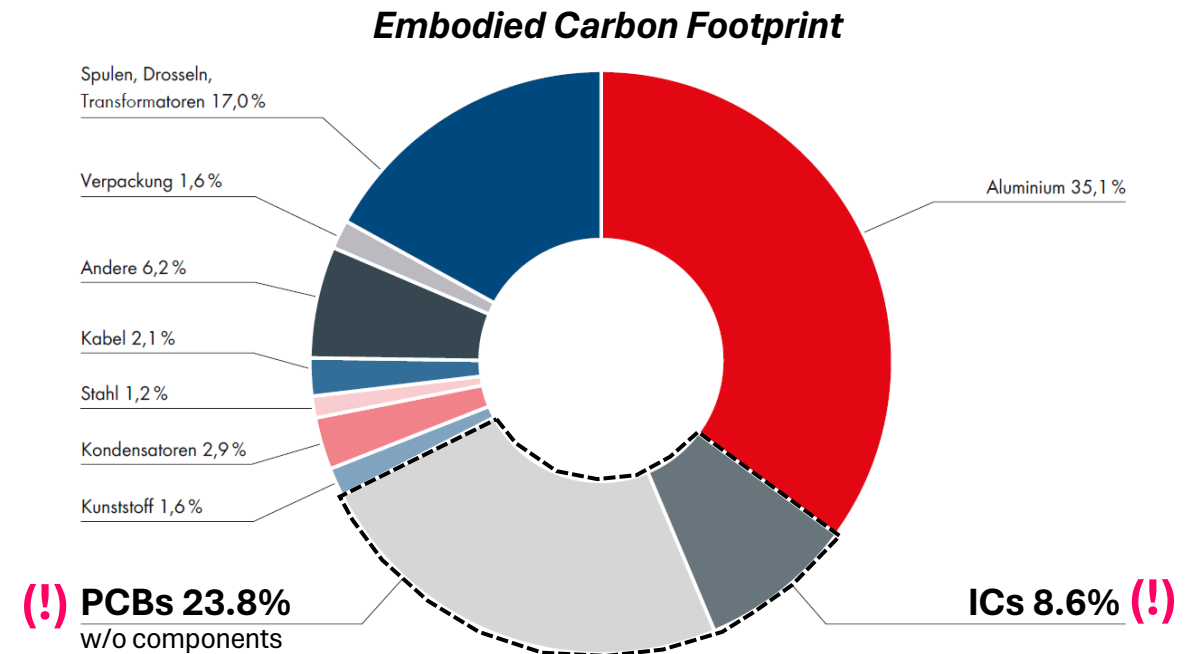
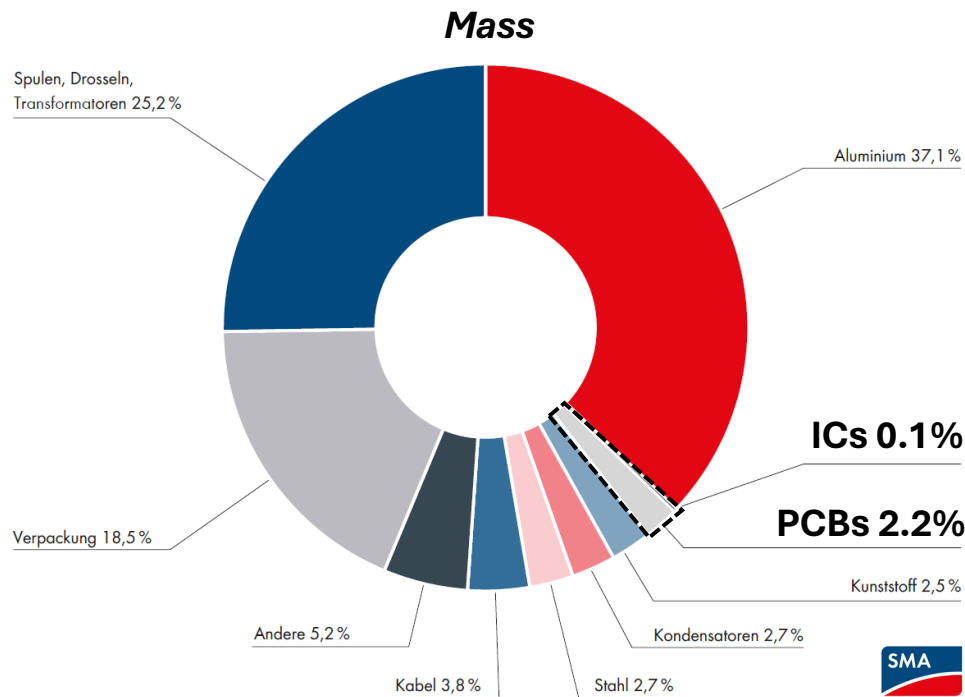

- **Small / lightweight components with large contributions to carbon footprint (!)**

# Carbon Footprint is Not Enough!

■ Life cycle **impact** assessment (LCIA) phase of LCA — **Environmental profile w. wide range of perf. indicators**

■ **Example: ReCiPe 2016**  
Three areas of protection / endpoint categories

● **Human Health**

Damage to Human Health (DHH)  
in Disability-Adjusted Loss of Life Years (DALY)

● **Ecosystem Quality**

Damage to ecosystem quality (DESQ)  
in Time-Integrated Species Loss (species · yr)

● **Resource Scarcity**

Damage to resource availability (DRA)  
in surplus cost / dollars (\$)

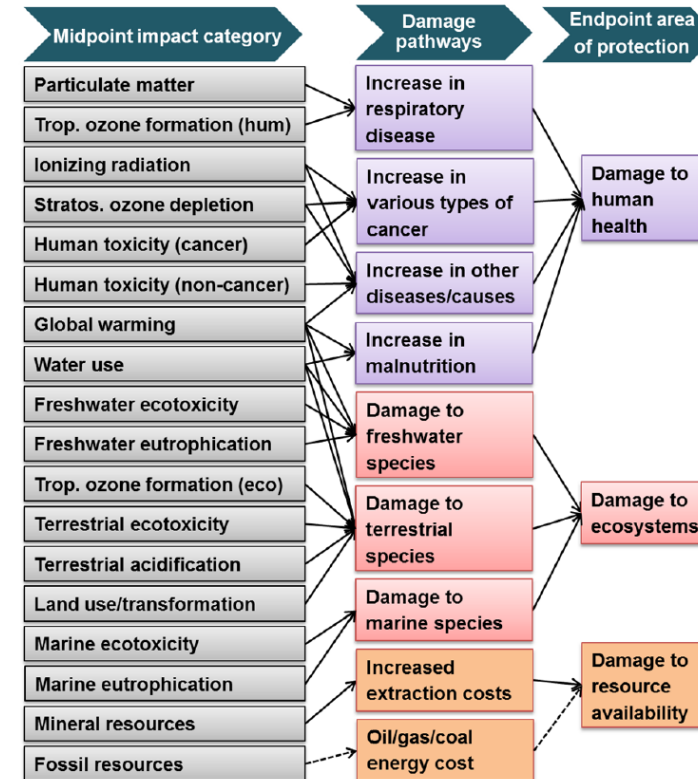

Source: Huijbregts et al., ReCiPe 2016 v1.1 Report

■ Value choices (**individualist / hierarchist / egalitarian**) affect time horizon, included effects, etc.

■ Alternative frameworks like **EU Environmental Footprint (EF 3.1)** exist

# LCA Example: 150-kW EV Drive Inverter (1)

- 150-kW inverter, 450 V DC bus 15 years / 10'000 operating hours w. avg. 97% efficiency (WLTP driving cycle)
- 16 Impact categories: **EU Product Environmental Footprint (PEF)**
  - **GWP:** Climate change (carbon footprint)
  - **MRD:** Resource use, minerals and metals, ...

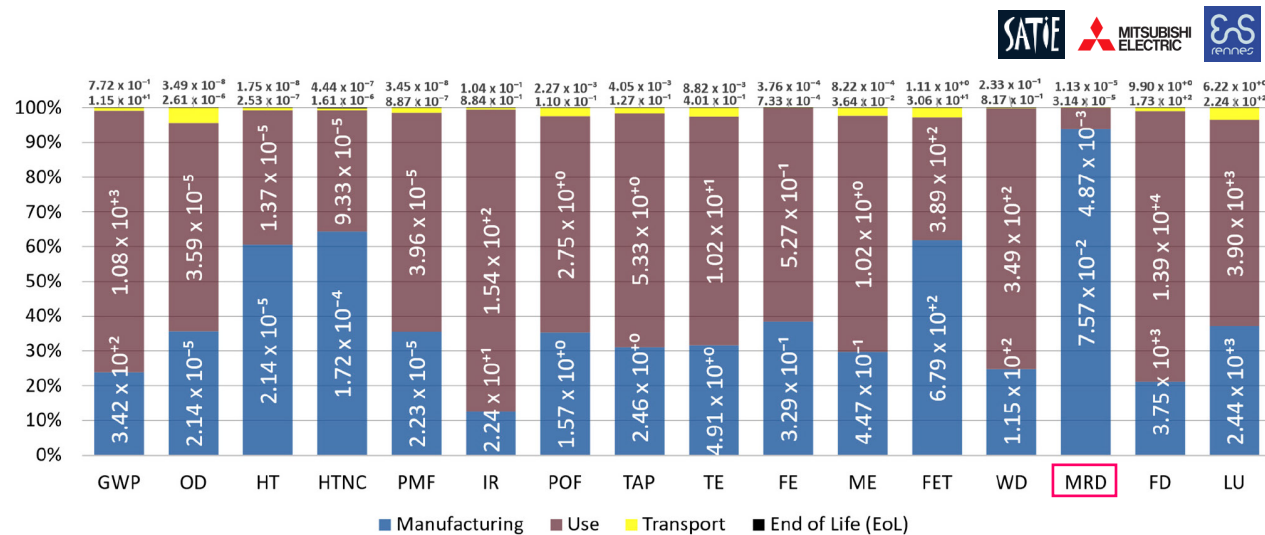
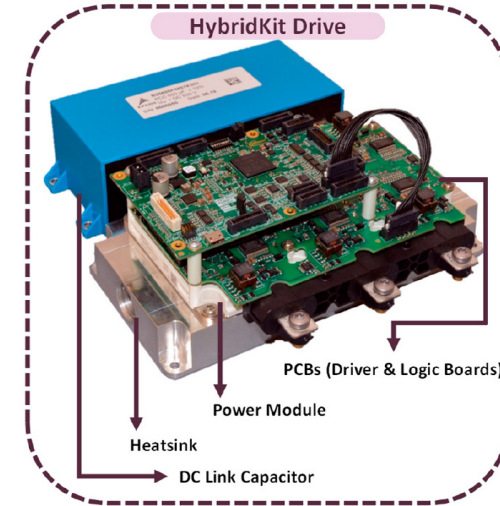

■ Production and use phase dominate all indicators

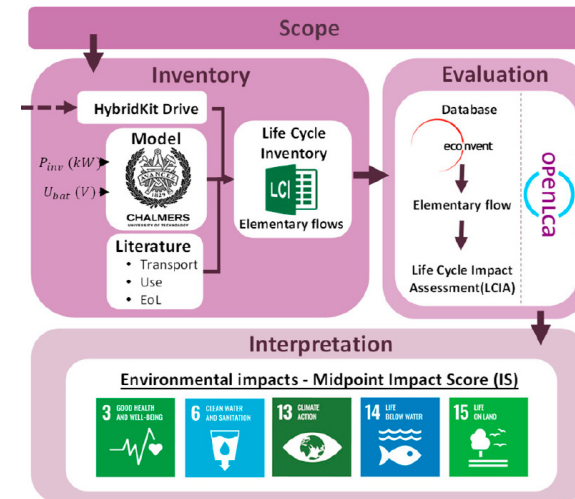

# LCA Example: 150-kW EV Drive Inverter (2)

- 150-kW inverter, 450 V DC bus 15 years / 10'000 operating hours w. avg. 97% efficiency (WLTP driving cycle)
- 16 Impact categories: **EU Product Environmental Footprint (PEF)**
  - **GWP**: Climate change (carbon footprint)
  - **MRD**: Resource use, minerals and metals,
  - ...

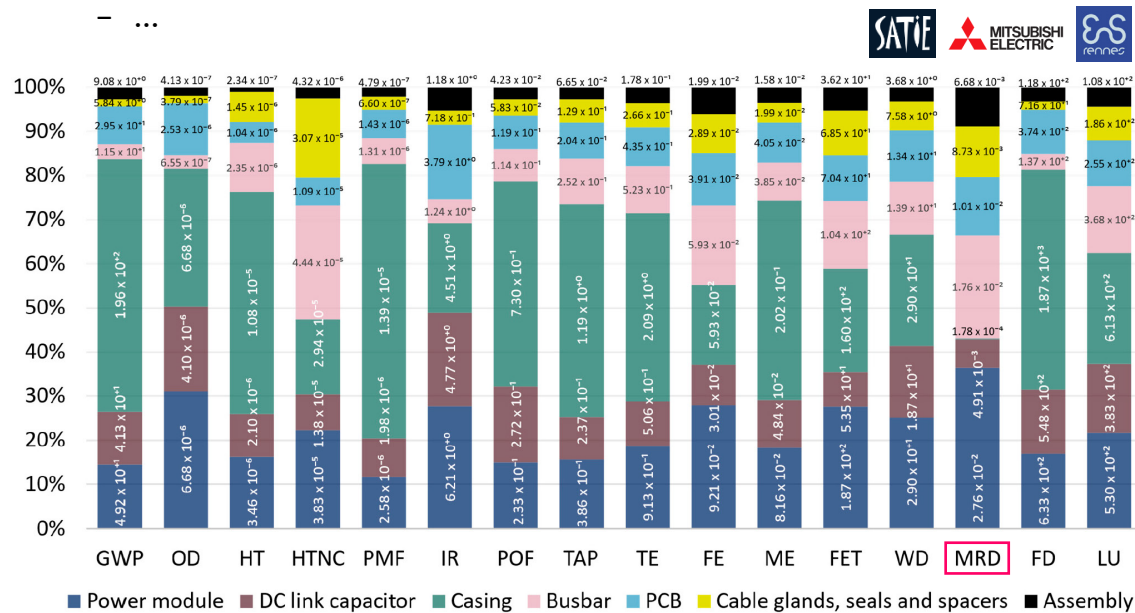

- Detailed **breakdown of component contributions to prod. phase**

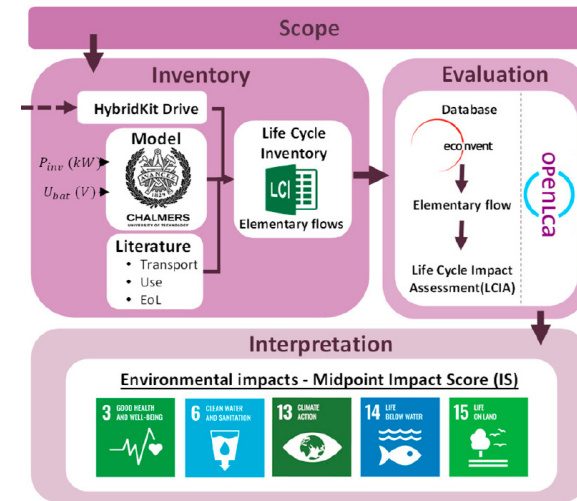
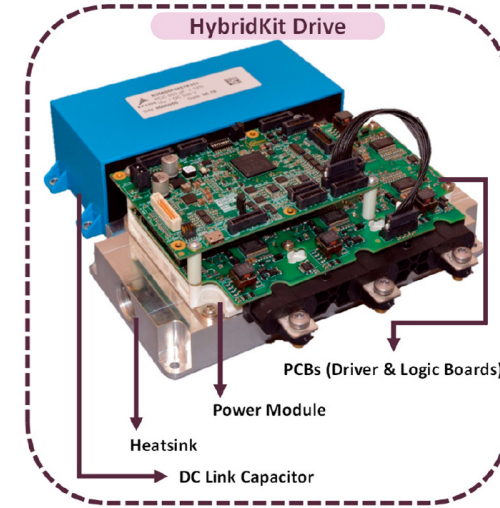



# New Holistic Design Procedure



Multi-Objective Optimization with Environmental Impacts as New Performance Indicators

# System Design Challenge

- Mutual coupling of performance indicators → Trade-off analysis!

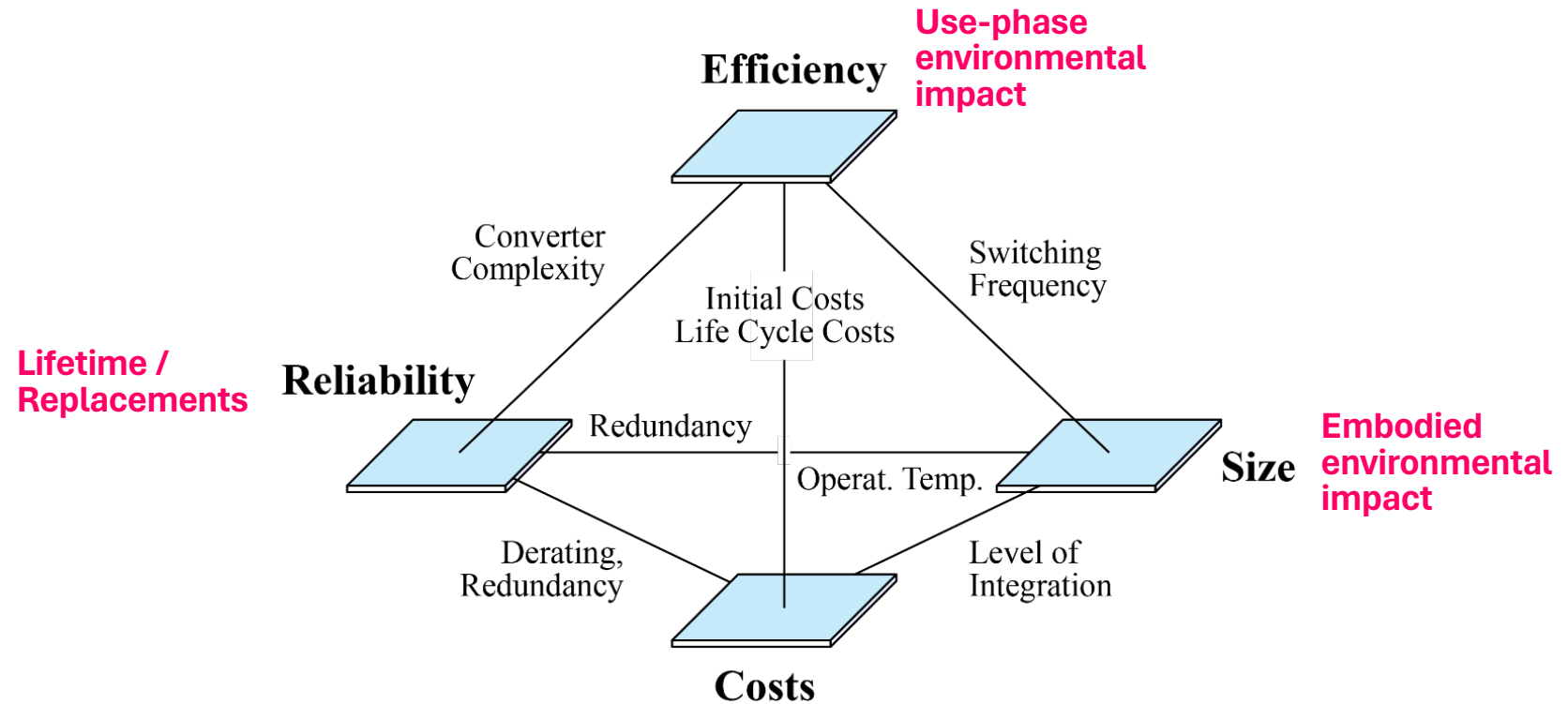

- For optimized systems, it is not possible to improve several perf. indicators *simultaneously*

# Abstraction of Power Converter Design

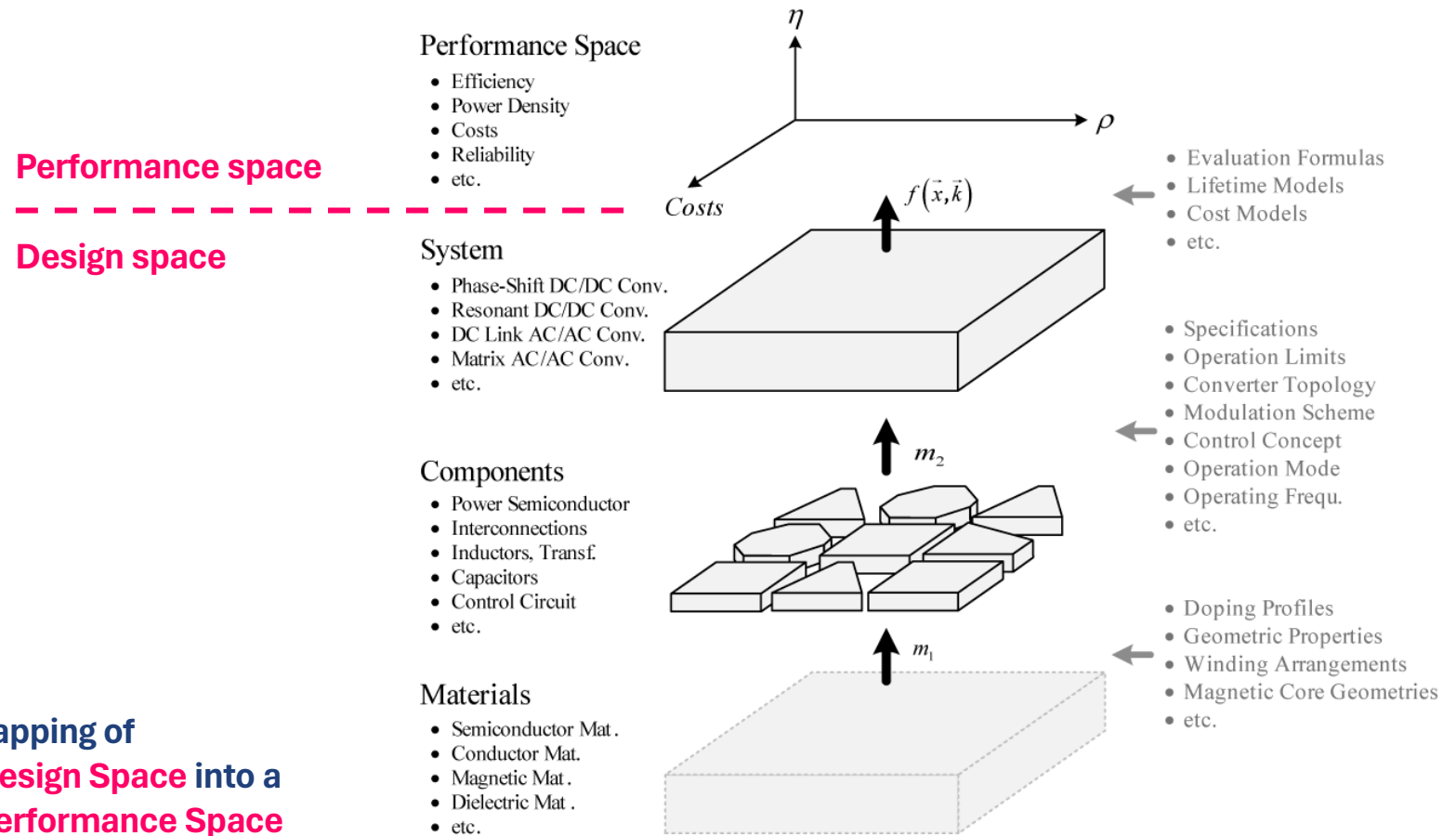

■ Converter Design: Mapping of Multi-Dimensional Design Space into a Multi-Dimensional Performance Space

# Modeling of Converter Designs

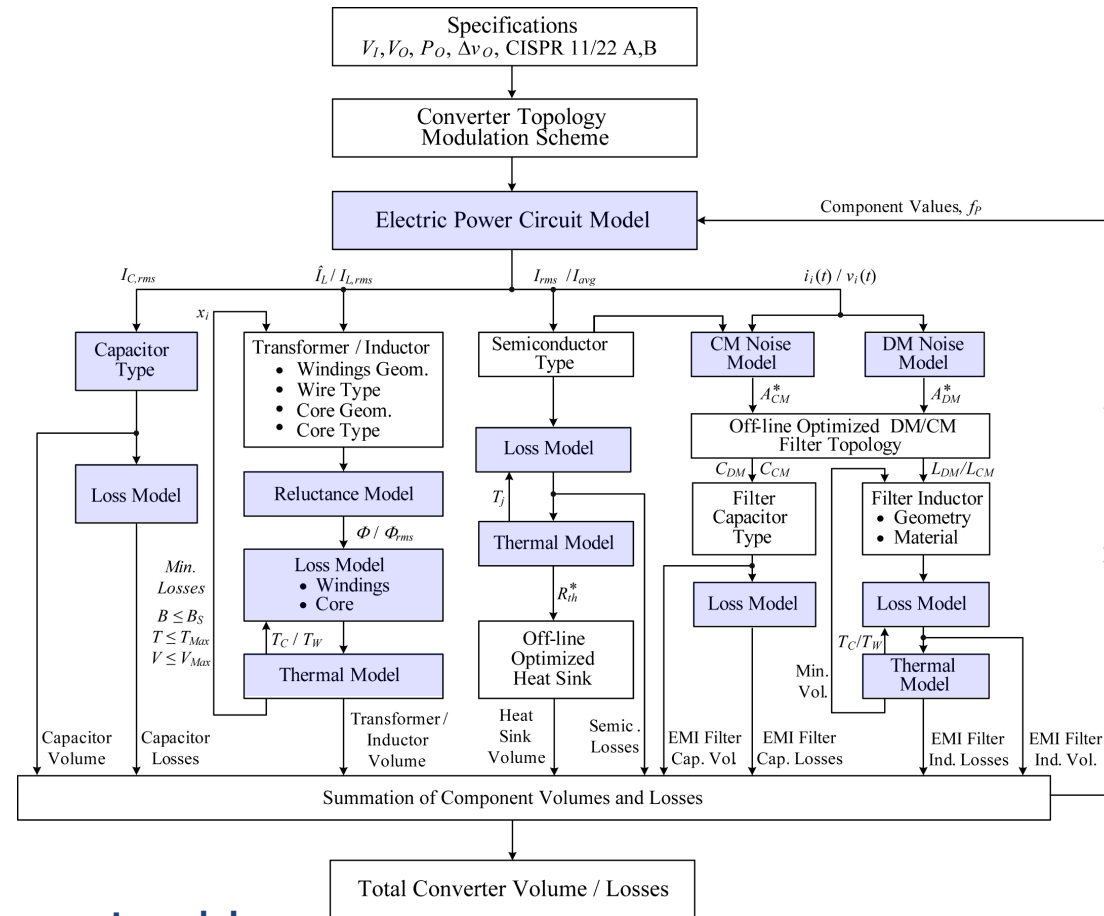

- System/circuit & component models
- Iteration over all combinations of design degrees of freedom

# Multi-Objective Optimization of Converter Designs

- **Pareto front:** Boundary of the feasible performance space
- **Mission profiles:** Power loss  $\rightarrow$  Energy loss / **Life-cycle cost (!)**

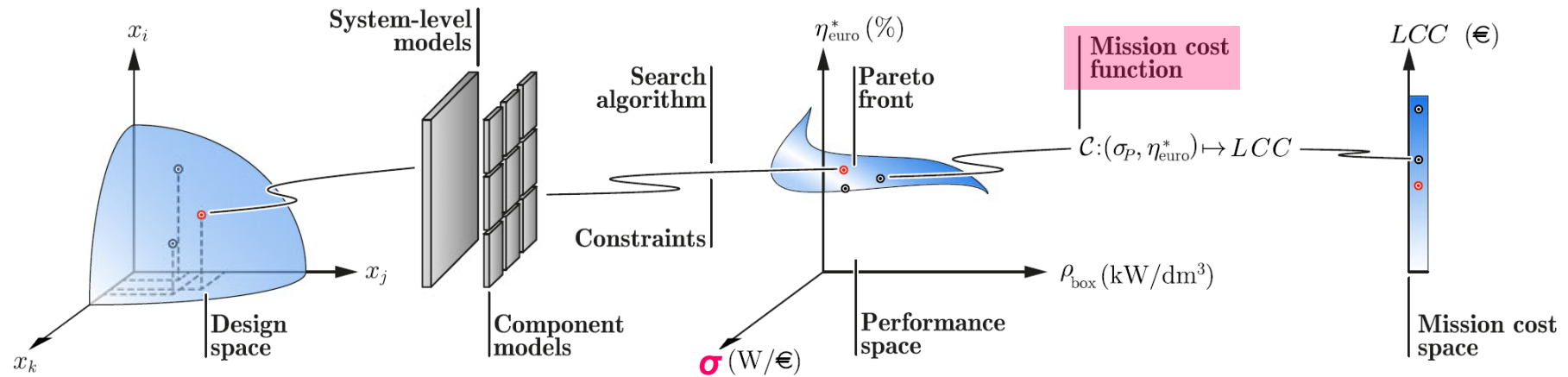

- **Typically considered performance indices:**
  - $\eta$  Efficiency in %
  - $\rho$  Volumetric power density in kW/dm<sup>3</sup>
  - $\gamma$  Gravimetric power density in kW/kg
  - $\sigma$  **Cost density in W/€**

# Design Space Diversity

- Very different design space coordinates map to very similar performance space coordinates

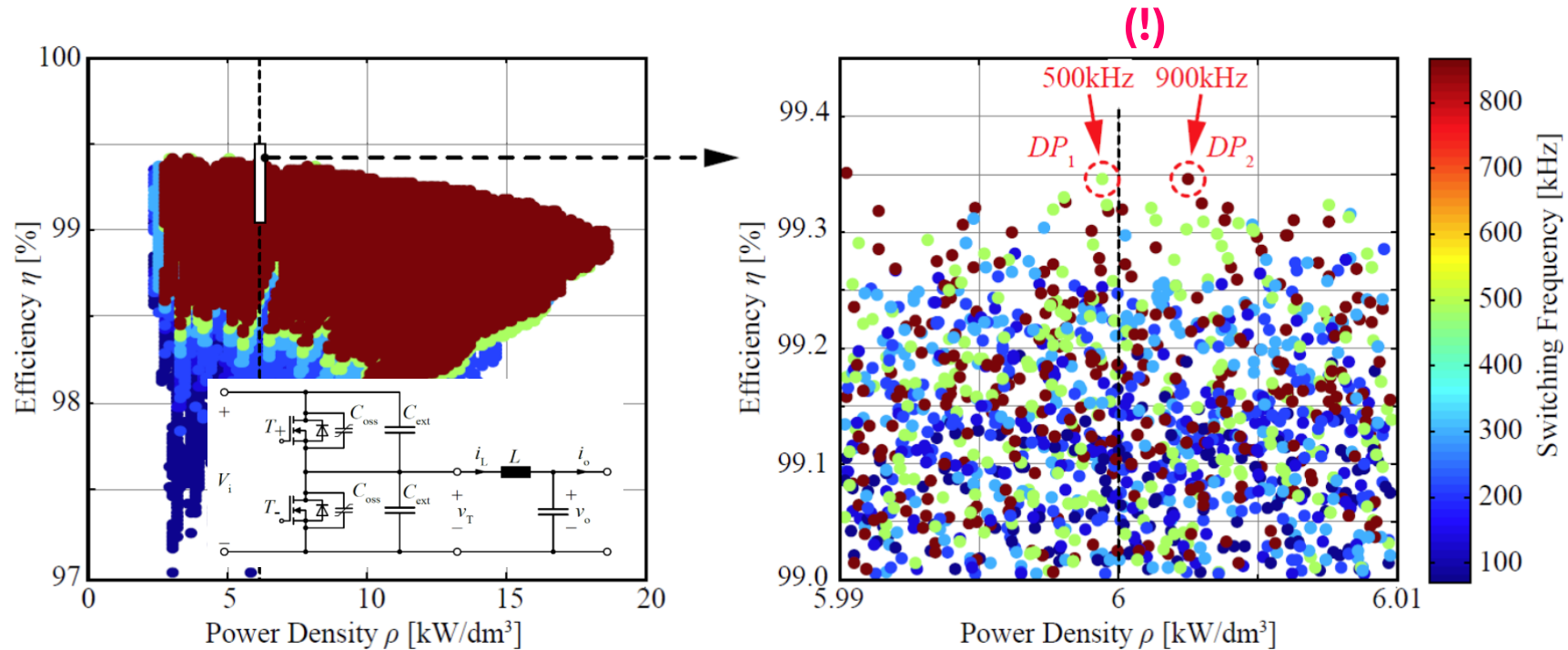

- Example: Google Littlebox design optimization w. PWM operation / Mutual comp. of HF and LF loss contrib.

# Design Space Diversity: 3L & 7L PV Inverters

Two concepts / similar specs — 12.5 kW, 650...720 V DC, CISPR 11 Class A — Similar perf. ( $\eta_{CEC} = 99.1\%$ )

**3-Level All-SiC T-Type PV Inverter** ★  
99.4%, 2.4 kW/dm<sup>3</sup>

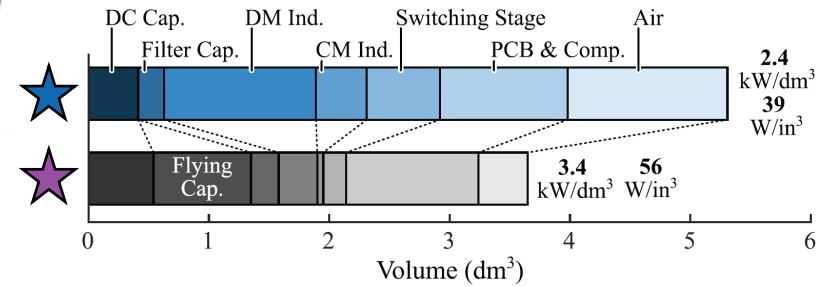
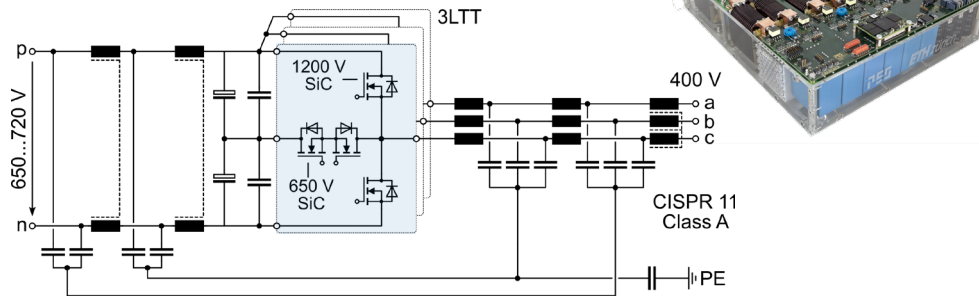

**7-Level All-Si HANPC PV Inverter** ★  
99.35%, 3.4 kW/dm<sup>3</sup>

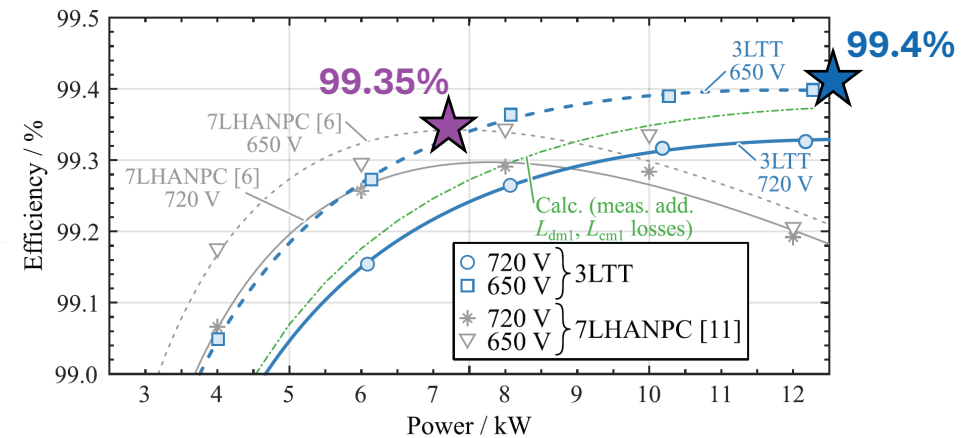
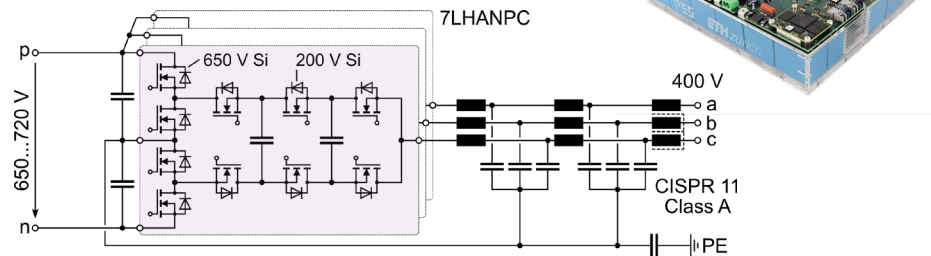

Differences in environmental impact?

# A Posteriori LCA of 3L & 7L PV Inverters (1)

■ Two concepts / similar specs — 12.5 kW, 650...720 V DC, CISPR 11 Class A — Similar perf. ( $\eta_{CEC} = 99.1\%$ )

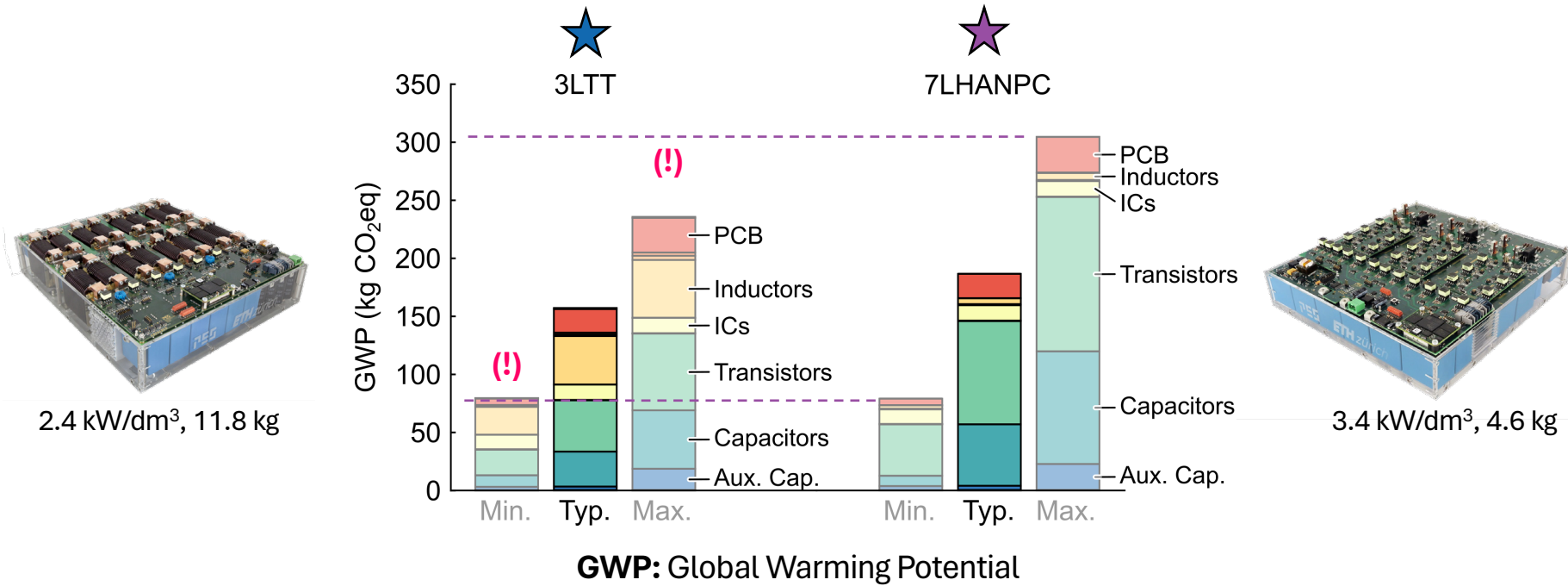

- Generic comp. models / ecoinvent database & lit. → Widely varying embodied carbon footprint (GWP) res. (!)
- Data availability / quality as key challenge!



# A Posteriori LCA of 3L & 7L PV Inverters (2)

- **Two concepts / similar specs** — 12.5 kW, 650...720 V DC, CISPR 11 Class A — **Similar perf.** ( $\eta_{CEC} = 99.1\%$ )
- **Life Cycle Impact Assessment (LCIA) w. ReCiPe framework:**
  - Damage to ecosystems (DESQ) | Damage to human health (DHH) | Damage to resource availability (DRA)

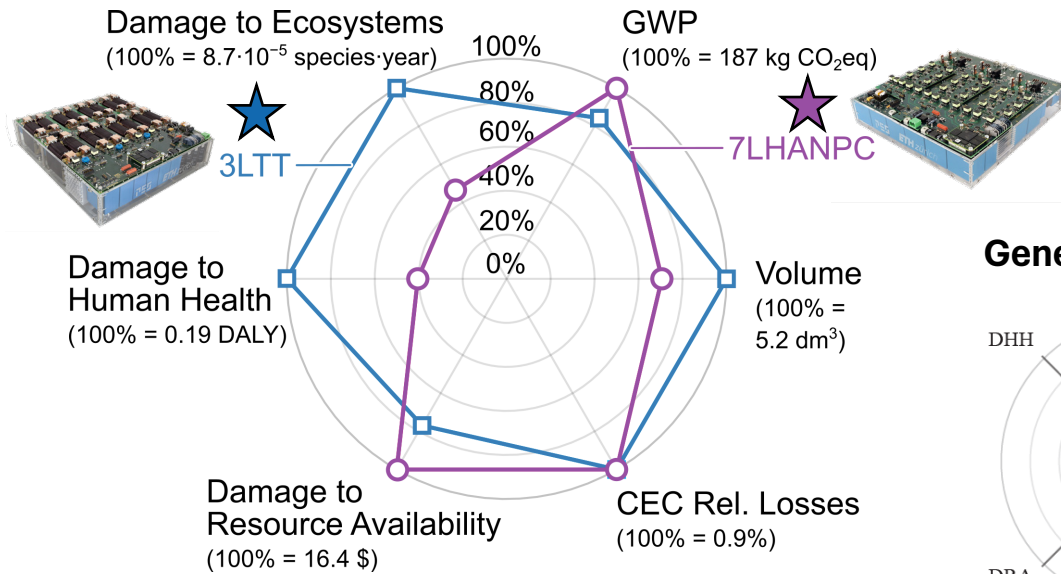

## Generic Comp. Mod.

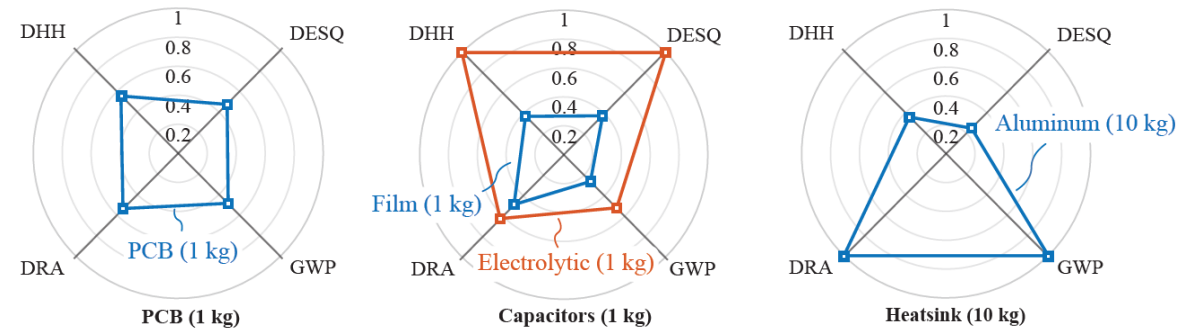

Normalized scales due to ecoinvent licensing restrictions.

- **Environmental footprint** of converter as aggregate of components' environmental footprints

**A Priori** Consideration of Environmental Impacts in the Design Process? 

# A Priori LCA Example: 10-kW Three-Phase AC-DC PEBB

- Key power electronic building block (PEBB) for three-phase PFC rectifiers & inverters

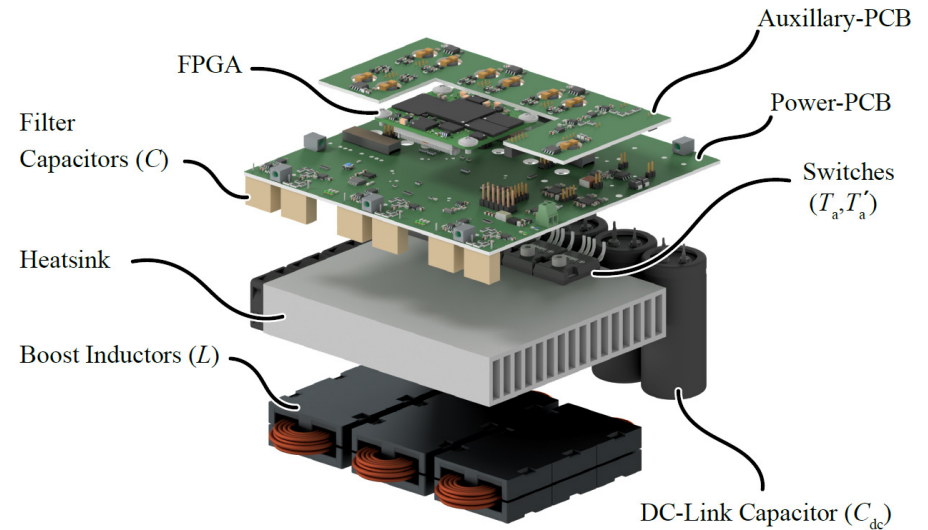
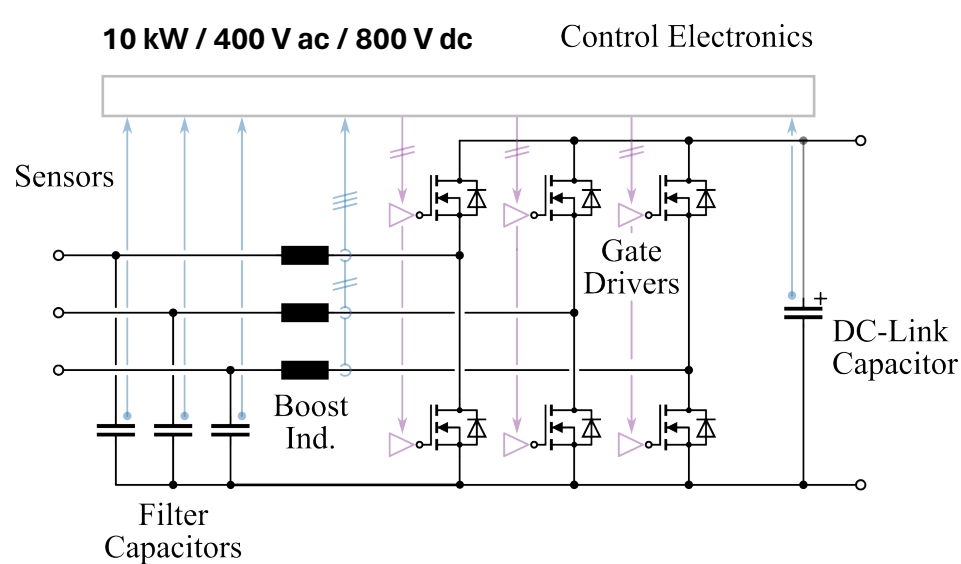

- **Degrees of freedom:**
  - Switching freq. [25...700 kHz]
  - Rel. Ind. Peak cur. ripple [0.25...1.5]
  - Var. transistor chip area
  - Variable ind. size (N87; solid/litz)

- **Assumptions:**
  - Junction temp. @ 120 °C
  - Ambient temp. 40 °C
  - Necessary heat sink vol. via CSPI = 25 W/(K dm<sup>3</sup>)

# Multi-Objective Optimization Including Env. Impacts (1)

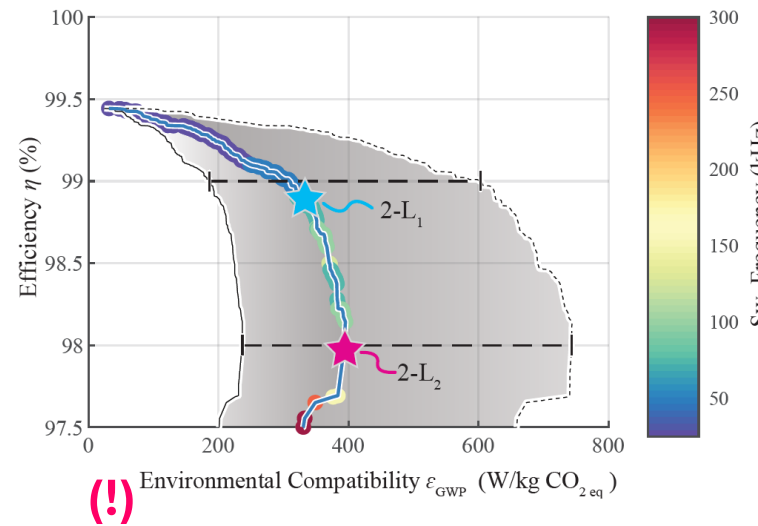
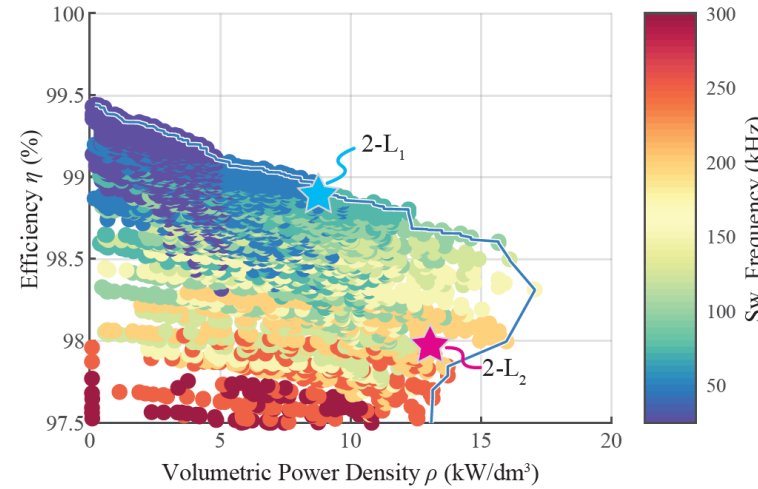
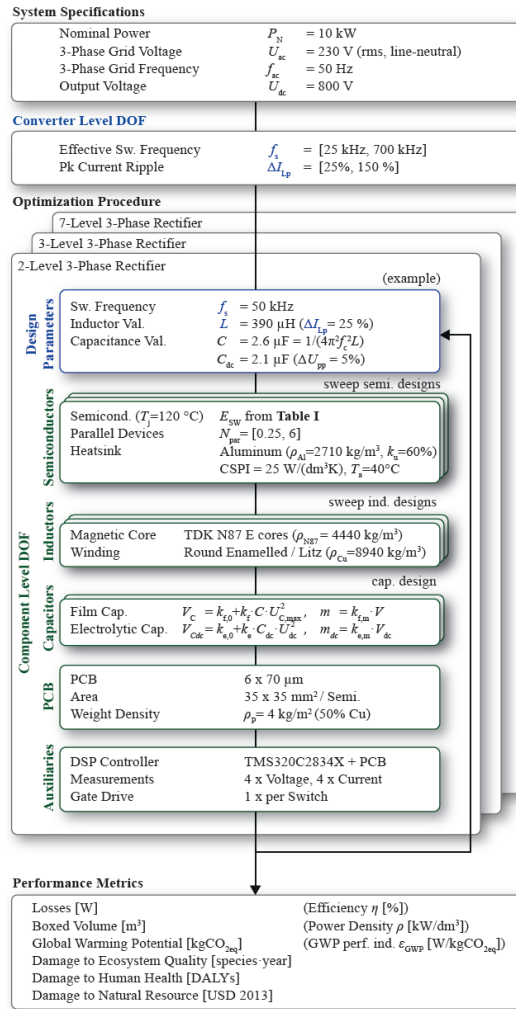

## Trade-Offs

- Efficiency vs. power density
- Efficiency vs. environmental compatibility regarding embodied GWP (carbon footprint)

## Env. Impacts with high uncertainties due to data availability/quality

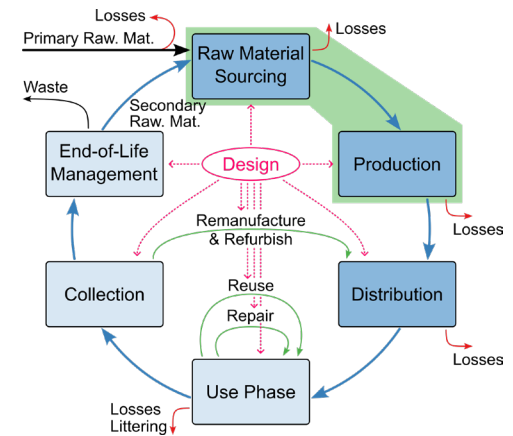

# Multi-Objective Optimization Including Env. Impacts (2)

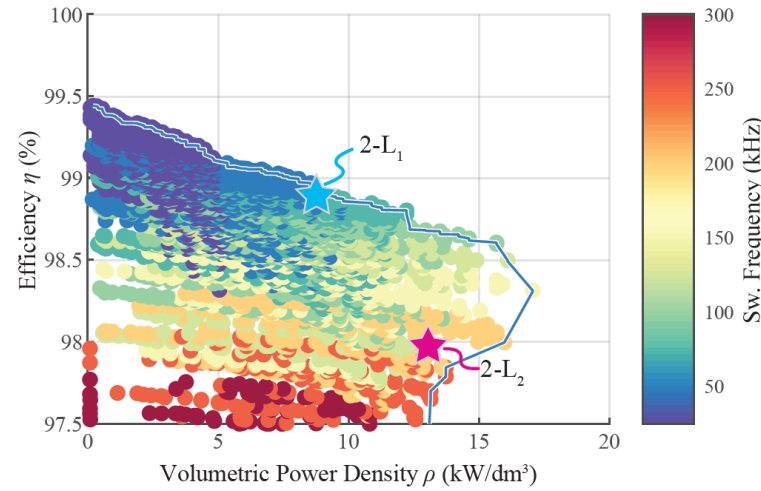
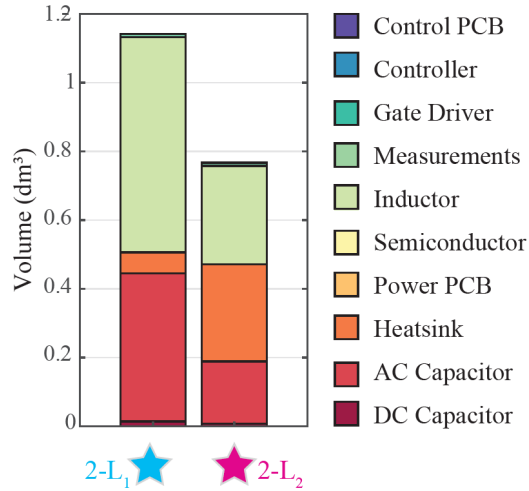

- Trade-Offs
  - Efficiency vs. power density
  - Efficiency vs. environmental compatibility regarding embodied GWP (carbon footprint)
- Env. Impacts with high uncertainties due to data availability/quality

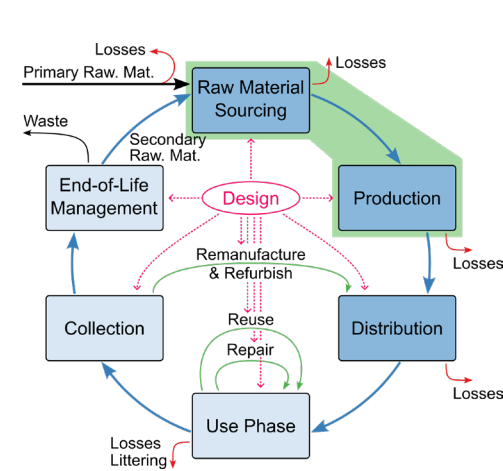
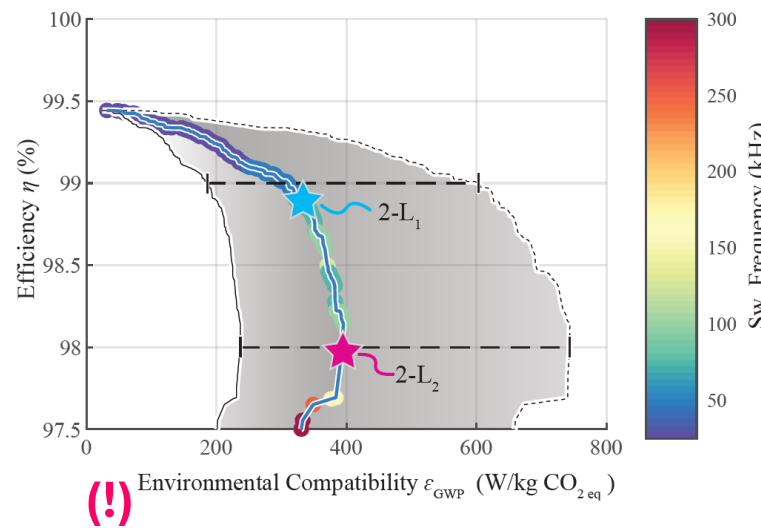
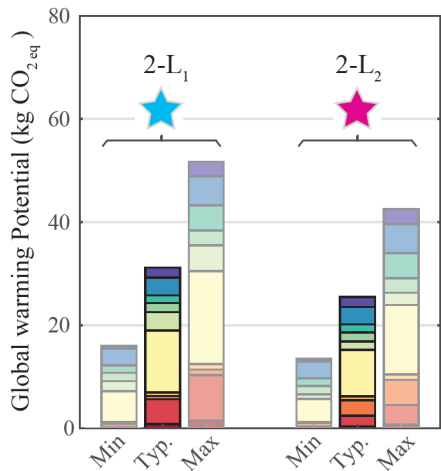

# Multi-Objective Optimization Including the Use Phase

Life-cycle carbon footprint strongly depends on electricity mix and mission profile / usage intensity

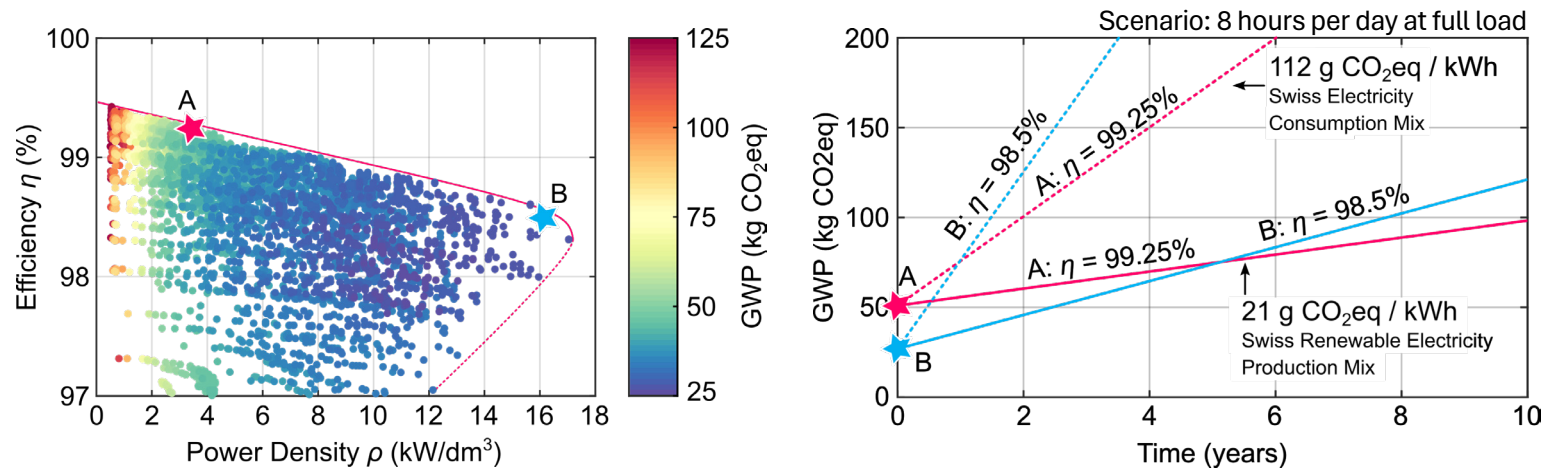

- Design should consider use phase for best life-cycle performance
- Analogy to total cost of ownership (TCO) perspective

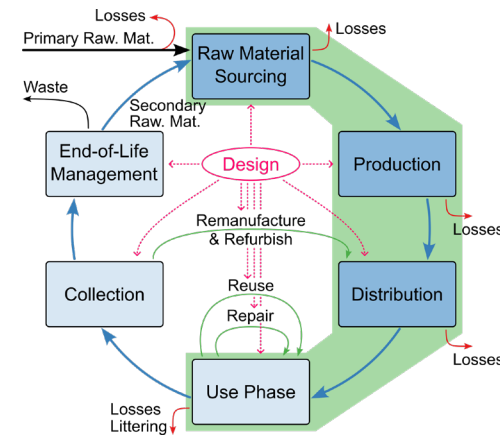
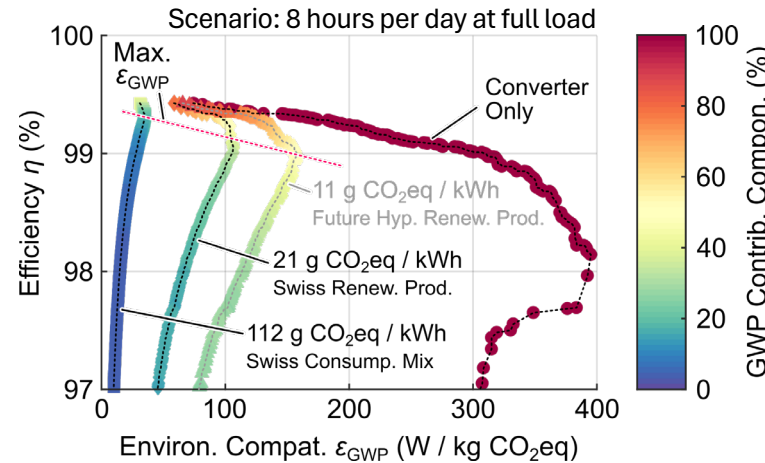

# Comprehensive Environmental Impact Profiles

- Different bridge-leg topologies — 2-Level (1200-V SiC) | 3-Level (650-V SiC) | 7-Level (200-V Si)

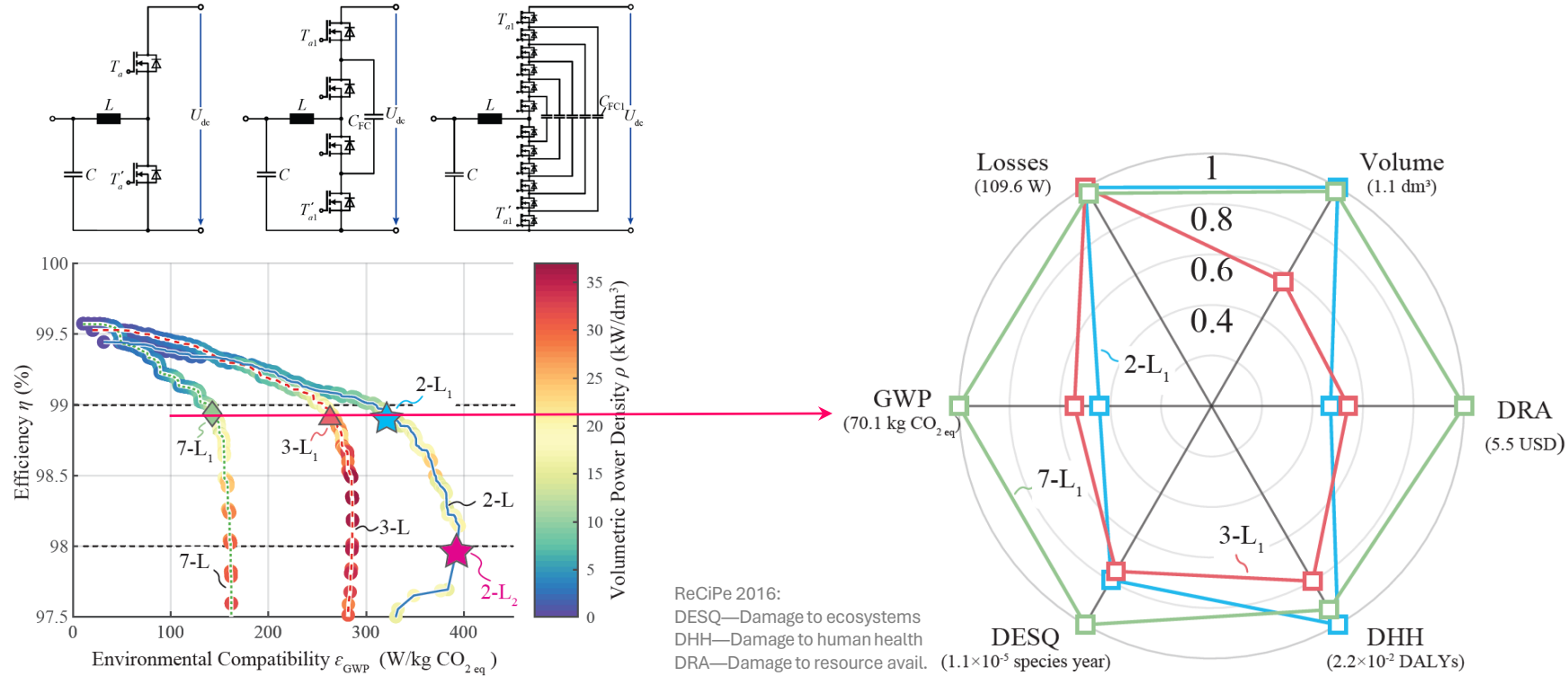

- Embod. env. footprint of 2L/3L/7L-designs with  $\eta \approx 99\%$  and max. env. compat.  $\epsilon_{GWP}$  in W / kg CO<sub>2eq</sub>
- Same efficiency via different usage of act./pass. components — Different environmental impact profile!

# Future Performance Indicators

- Assuming 20+ years lifetime → **Systems installed today reach end-of-life by 2050 (!)**
- Life cycle assessment (LCA) mandatory for all future system designs

## ■ Complete set of new performance indicators

- Environmental impact [kg CO<sub>2</sub>eq / kW, ...]
- Resource efficiency [kg<sub>xx</sub> / kW]
- Embodied energy [kWh / kW]
- TCO [\$ / kW]
- Power density [kW/dm<sup>3</sup>, kW/dm<sup>2</sup>]
- Mission efficiency [%]
- Failure rate [h<sup>-1</sup>]

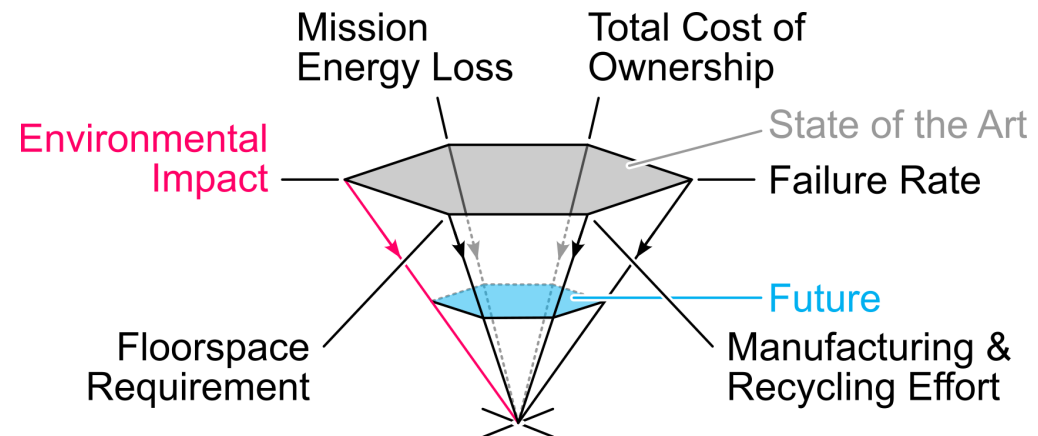

- Mission/location-specific **trade-off embod.** vs. **life-cycle environ. impact** — Losses / Reliability / Lifetime
- Compatibility with a circular economy (!) — **Repairability / Reusability / Recyclability**



# Remark: Ageing Modeling and Environmental Impacts (1)

- IGBT module / 30 yr / 20'000 op. hours WLTP cycle
- Life-cycle environmental impacts with (probabilistic) ageing models (Coffin-Manson) & replacement
- Focus on MRD — Resource use, minerals and metals

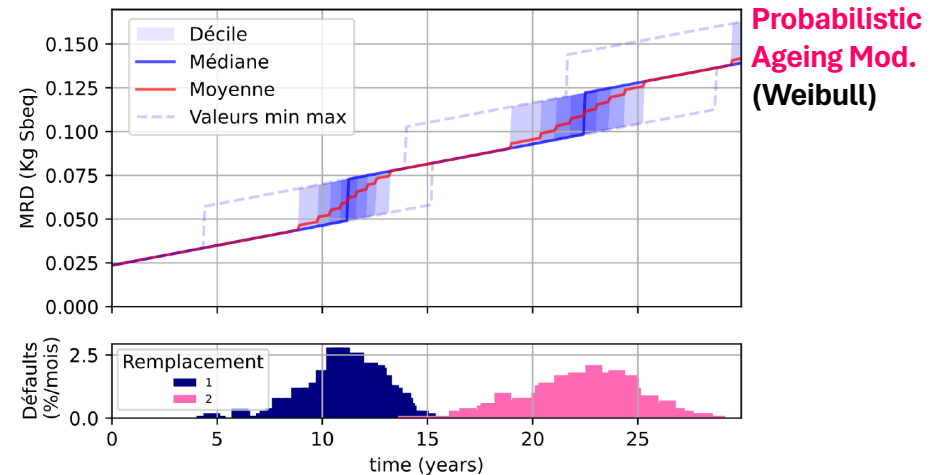
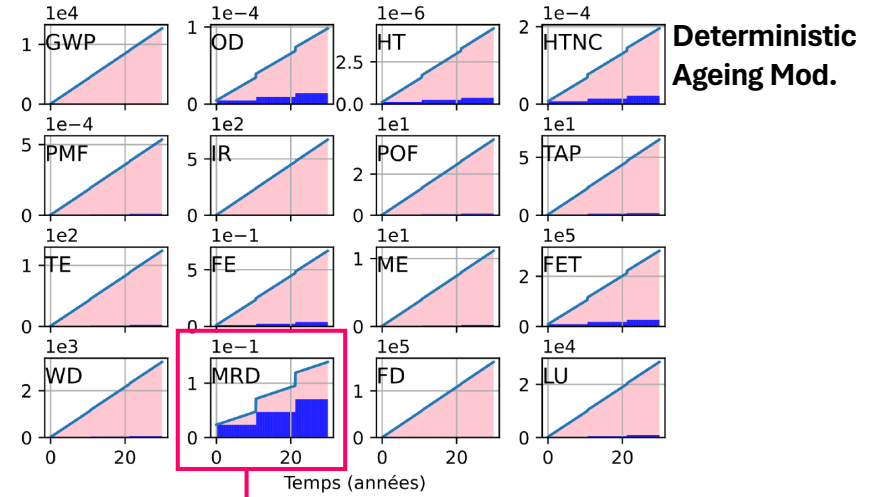
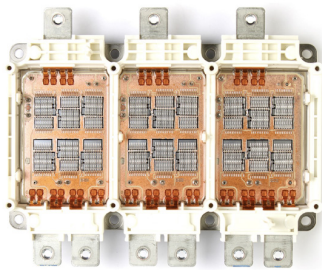
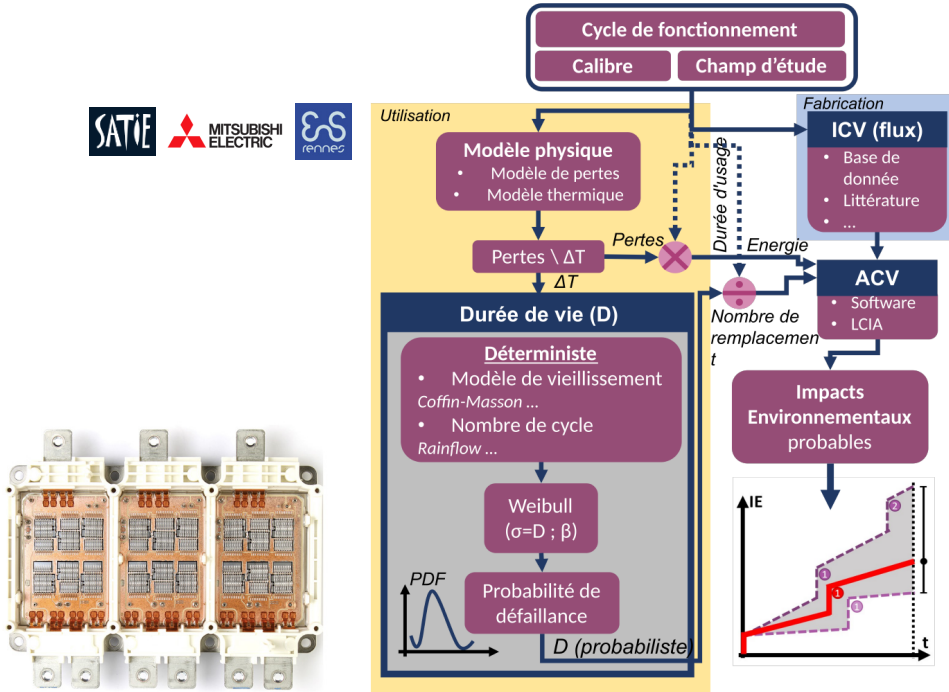

## Remark: Ageing Modeling and Environmental Impacts (2)

- Larger heat sink: **Higher realization effort** ↔ Lower temperatures and **slower ageing**
- IGBT module / 30 yr / 20'000 op. hours WLTP cycle

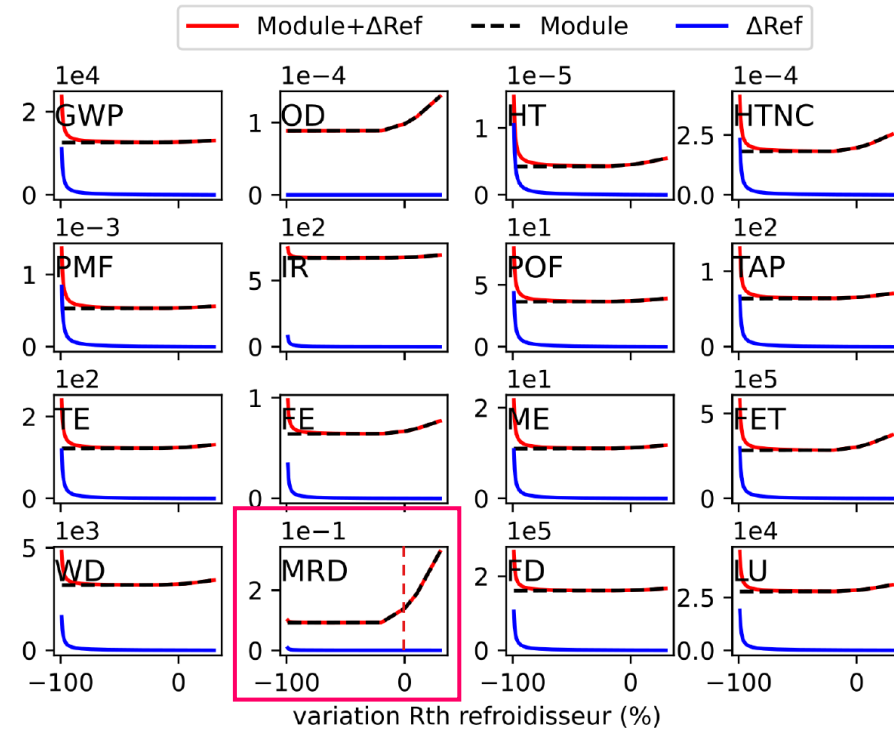
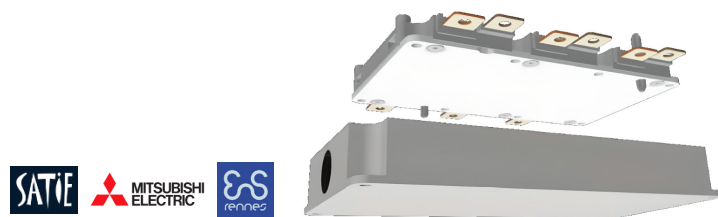

- **Optimum thermal resistance  $R_{th}$  (heat sink size) exists!**

# “Closing the Loop”

- Including **4R** into the design process — **Repair / Reuse / Refurbish / Recycle**

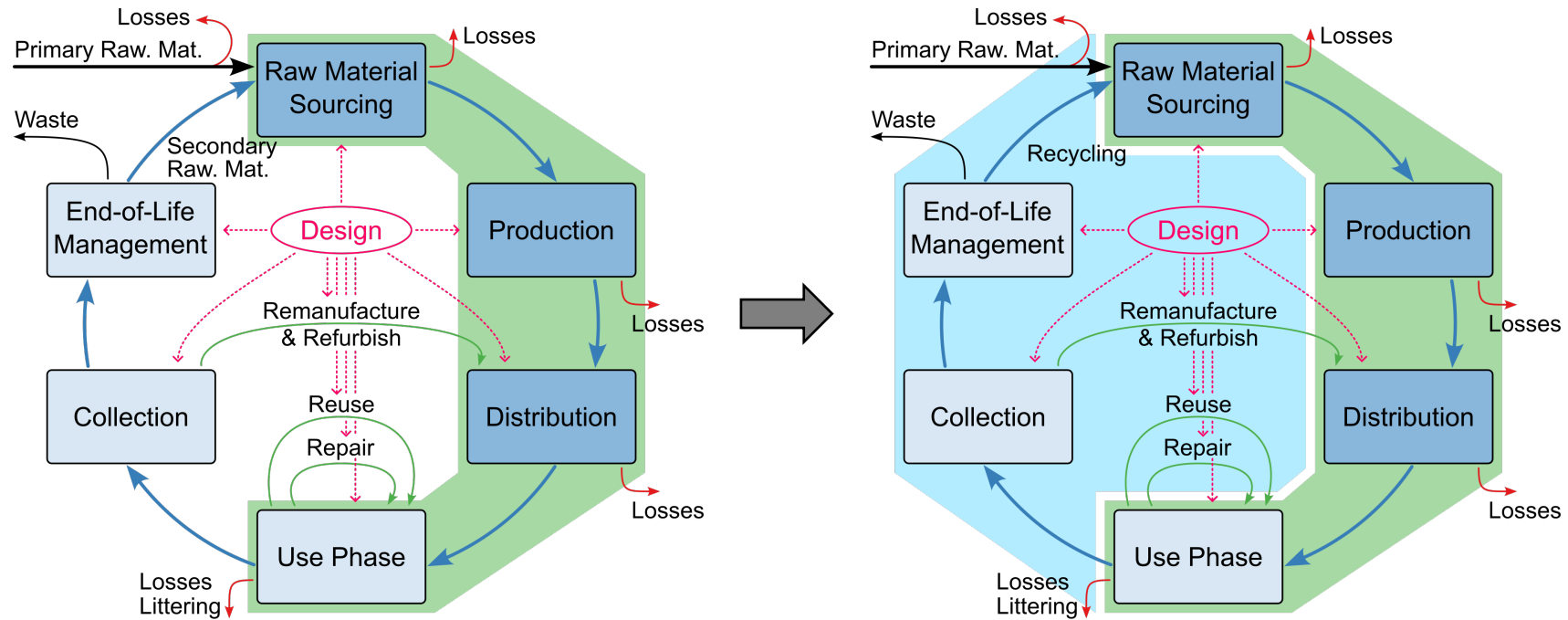

- **How to quantify** repairability / reusability / ...?
- Value proposition through life-cycle cost perspective (suppliers *and* customers)?

# Recycling Potential of On-Board Chargers

■ Theor. **best-case** mass-based **end-of-life recycling rates** (EOL-RR) for GaN-based 3.7-kW EV OBC

EOL-RR for Sel. Elements

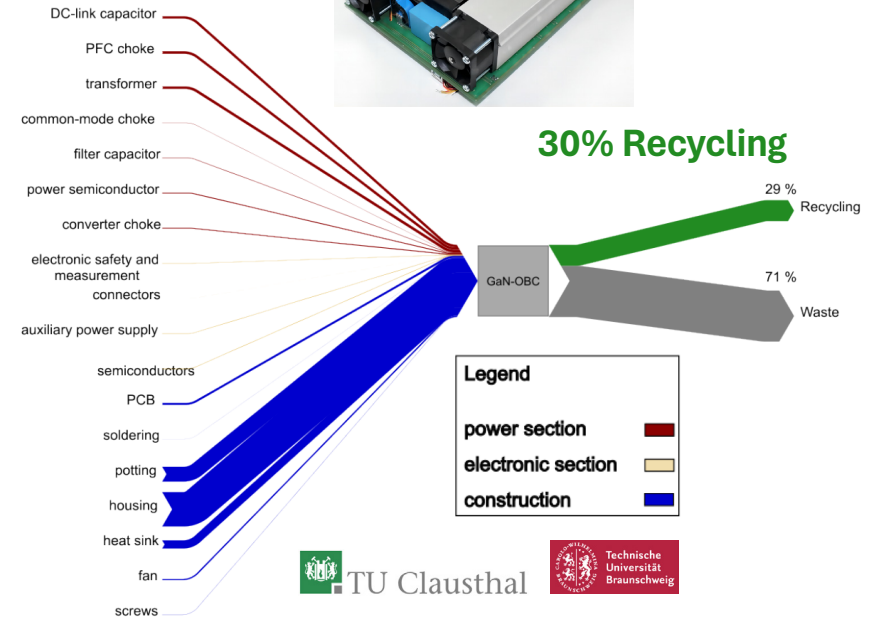
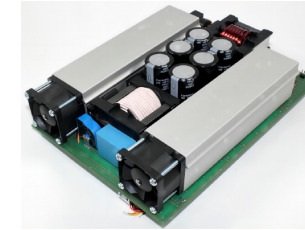
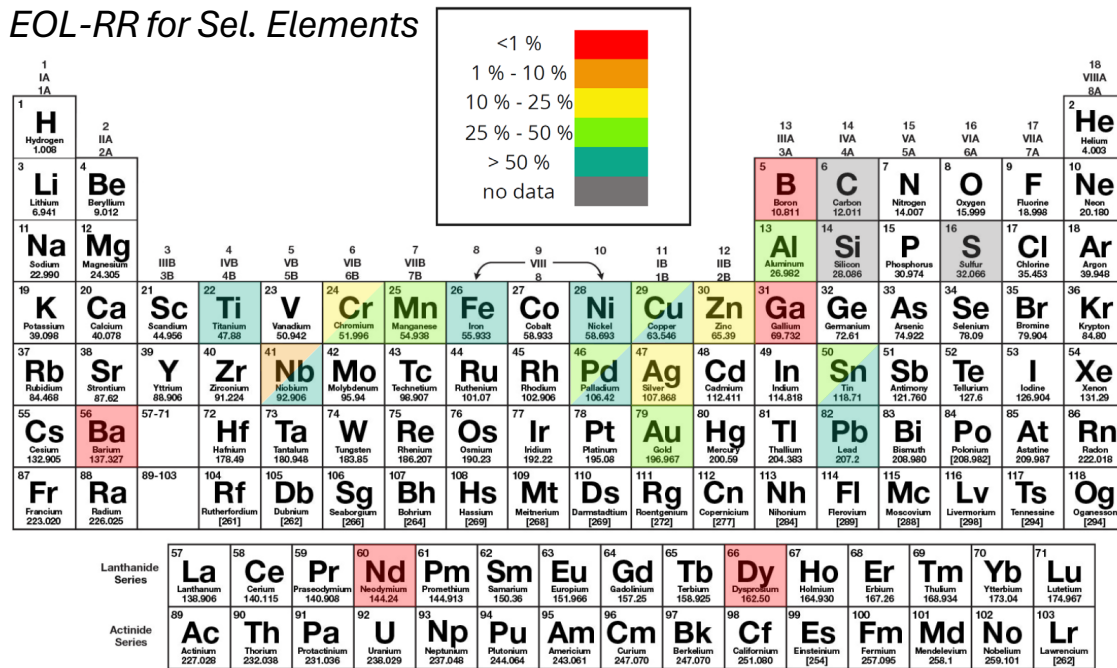

● EOL-RR data availability / quality: Only for metals, wide range of reported values

Source: C. Minke, R. Mallwitz, P. Burfeind, and D. Hu, "Recycling potential of power electronics solutions - an exemplary study about on-board chargers," in Proc. 13th Int. Conf. Integrated Power Systems (CIPS), Düsseldorf, Germany, Mar. 2024.

## Remark: Electronic Component Reclaim / Reuse

- Electronic waste recycling today: Shred / incinerate / extract most valuable resources — if at all!
- Alternative: **Reclaim & refurbish** / Desolder & re-ball

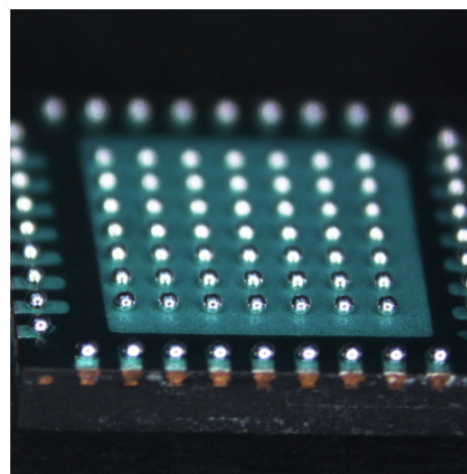
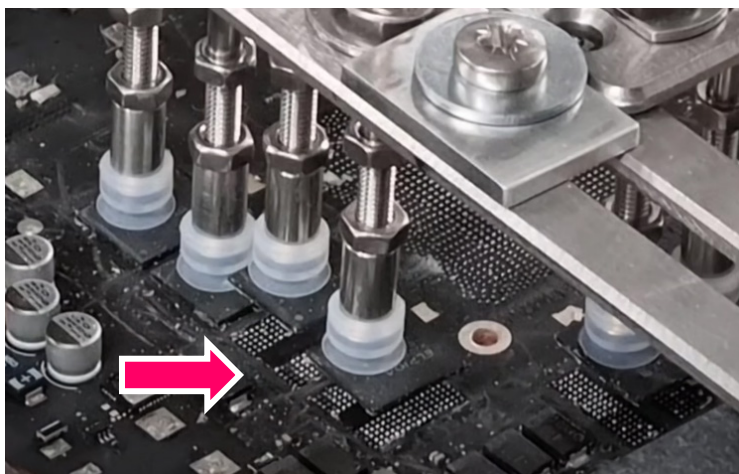

- Challenging logistics etc. for reclaiming PCBs from customers / Circular economy thinking needed
- Business case today especially for **scarce / valuable components**

# Sustainability Potential

■ 2<sup>nd</sup> ELLEN MACARTHUR FOUNDATION circular economy principle: Circulate products and materials at their highest values

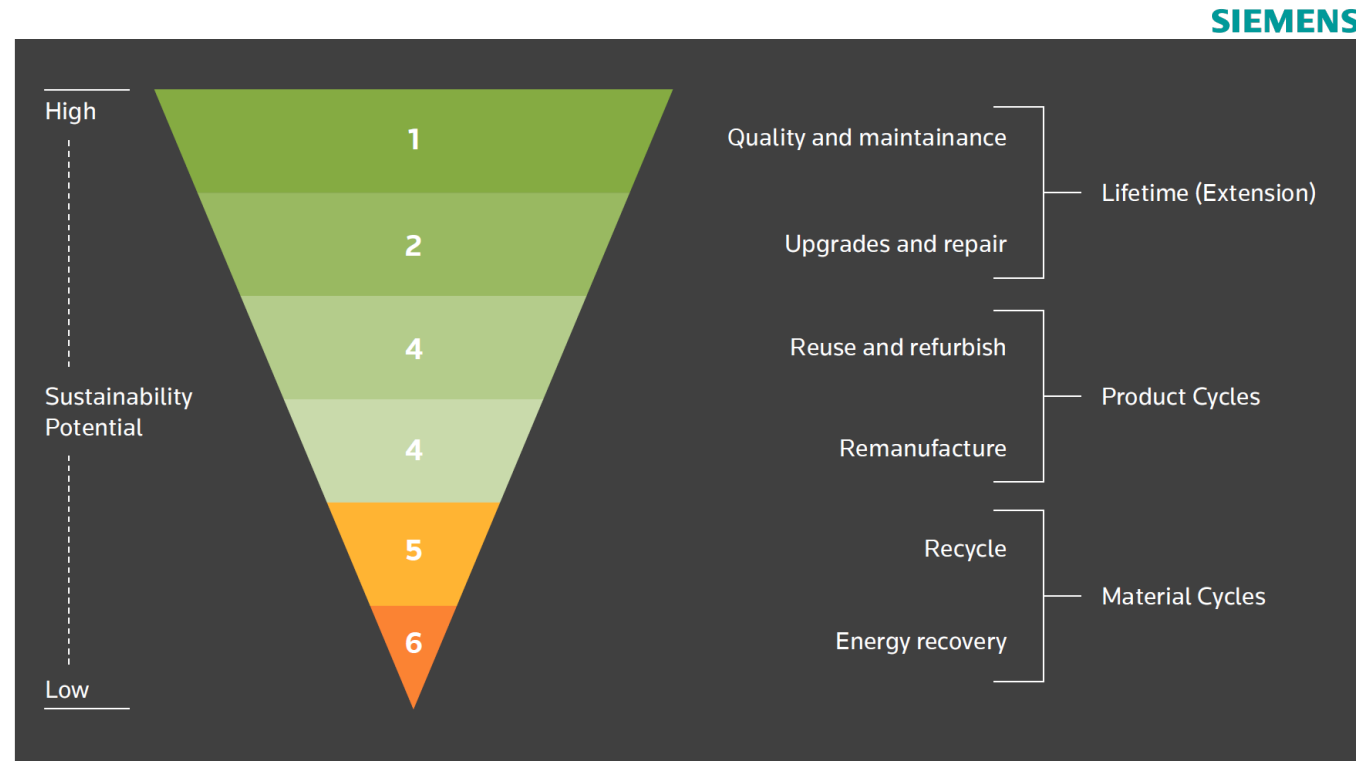

■ High reliability / lifetime extension → Lifetime / aging modeling

# Modularity: Upgrade, Reuse, Repair, ...

- Module design for ease of disassembly: **Maintainability, upgradability, repairability, reusability, recyclability**

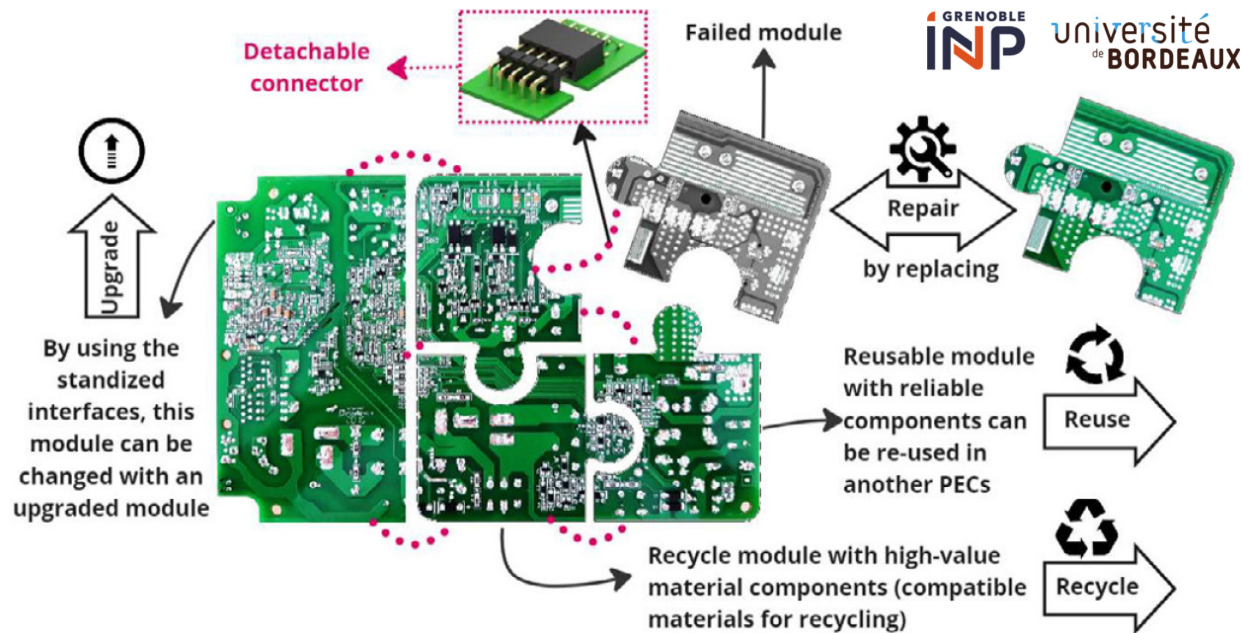



- **Grouping of components** according to reliability level and expected lifetime / level of reusability or recyclability / ...
- Standardized interfaces / **Mechanically loose connections** ↔ **Electrical characteristics**
- Potential for leveraging economies of scale to compensate interface costs

# Integration: Minimize Size / Initial Resource Usage

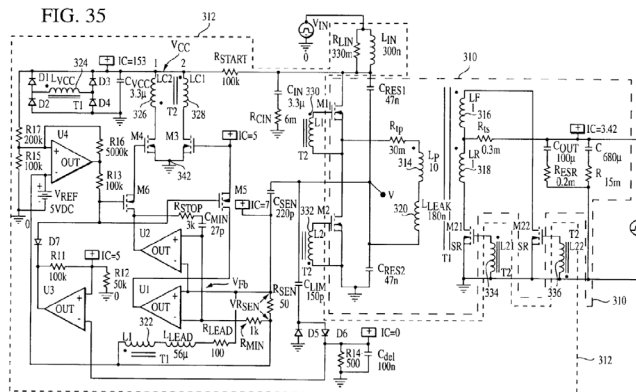
- **Maximum integration facilitates extreme power densities (10...100 x conv.)**
- Example: **30 kW** non-isolated fixed-ratio conversion (**400 V to 800 V**) in **92 x 80 x 7.4 mm<sup>3</sup>** — **550 kW/dm<sup>3</sup>** and **130 kW/kg**
- **Low initial material usage** ↔ **Difficult material separation**
- **Importance of recyclability?**

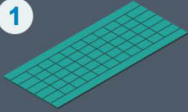
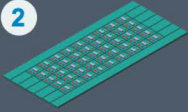
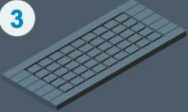
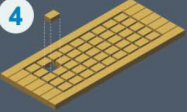

Example: Isolated dc-dc

1	2	3	4	5
 <p><b>Bare panel</b></p>	 <p><b>Surface mounting</b></p>	 <p><b>Overmolding</b></p>	 <p><b>Plating</b></p>	 <p><b>CHIP modules</b></p>
<p>The process begins with a bare panel, ready for multiple instances of the same high-performance module, analogous to a silicon wafer</p>	<p>High-quality power components, including magnetics, are mounted and soldered via state-of-the-art pick-and-place tools</p>	<p>A plastic compound encases the panel, protecting the components and creating a flat surface that makes the final product easier to handle</p>	<p>Heat conducting metals are plated onto the panel to enable a thermally efficient and reliable finished product</p>	<p>The panels are singulated into individual modules and tested for conformance to data sheet specifications</p>



# CEC Power Electronics Roadmap

- **Environmental awareness** as integral part of **environmentally conscious power electronics design**

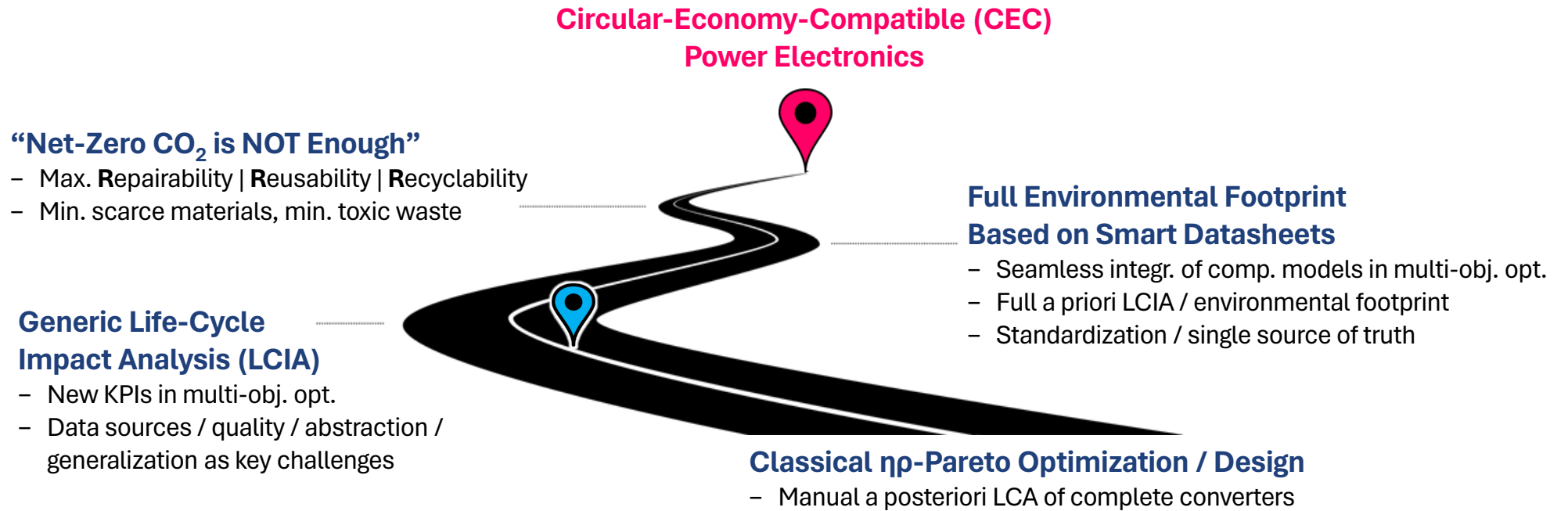

- **Automated design** | **On-line monitoring** | **Preventive maintenance** | **Digital product passport**

# Power Electronics 5.0

- Power Electronics 1.0 → Power Electronics 5.0
- X-Technologies & X-Concepts
- New main performance indicators (!)

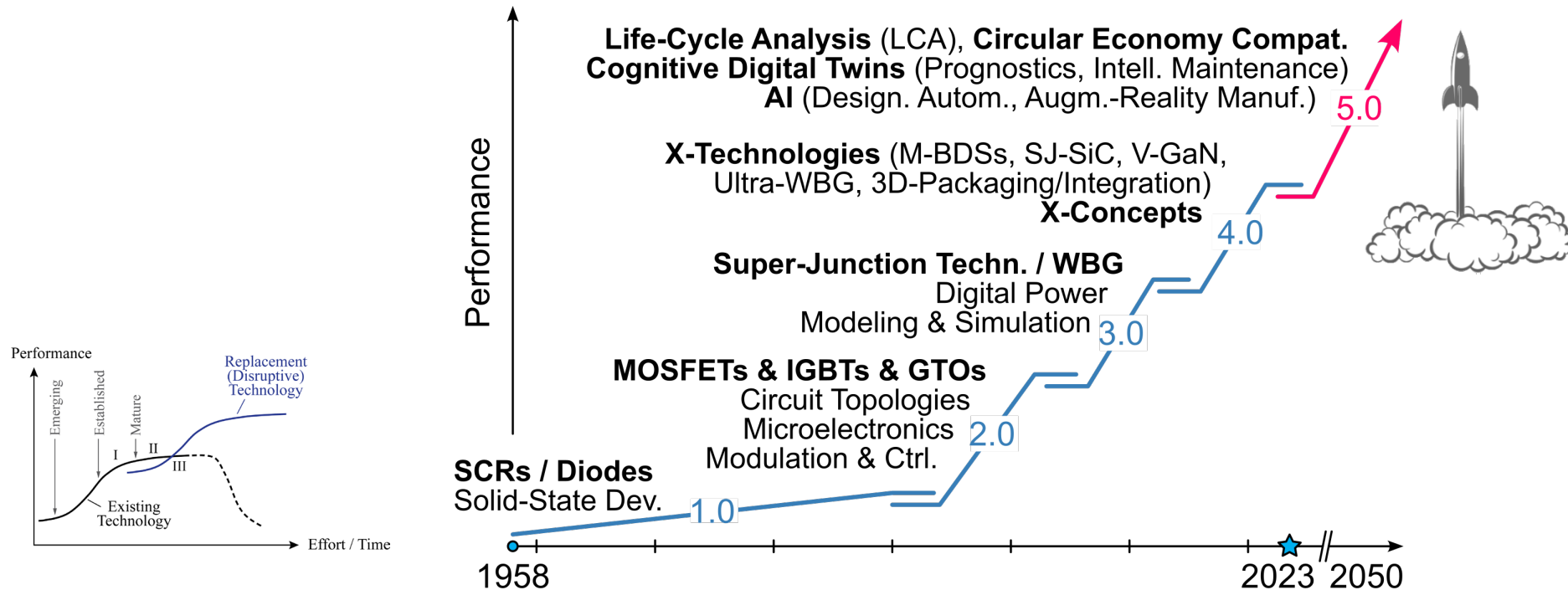

- Life-cycle analysis / Circular economy compatibility are key for sustainable Power Electronics 5.0

# Thank You!

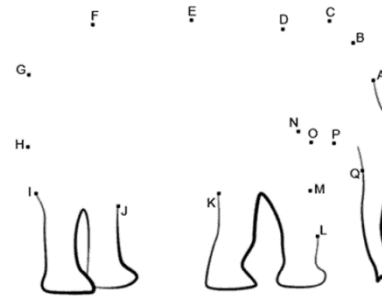

## Abstract

Limiting global warming necessitates the renewable energy transition, i.e., a new net-zero-CO<sub>2</sub> energy system that will be mostly electric. This implies a massive expansion of the electric grid infrastructure in general and a massive deployment of power electronic converter and energy storage systems in particular. However, converter systems installed today will reach their end of life typically before 2050, i.e., before the commonly accepted date for reaching the net-zero-CO<sub>2</sub> target. Given the sheer scale of the future all-electric energy system, the maintenance/replacement effort might thus deplete scarce raw material resources and cause large volumes of (electronic) waste and associated environmental problems if the current linear economy approach (take-make-dispose) is maintained. Instead, a transition towards a circular economy is mandatory to ensure that the net-zero-CO<sub>2</sub> target is reached on a sustainable basis, i.e., with minimized environmental impact.

Clearly, established power electronics design procedures focused on maximum power density or maximum efficiency are not adequate anymore. Therefore, this short course first introduces life-cycle assessments (LCAs) of power electronic converter systems to quantify environmental impacts (carbon footprint, release of toxic substances, etc.) embodied in a system and accrued during the use phase due to conversion losses. Using exemplary three-phase converter systems (PV inverters and motor drives), we then extend the commonly employed multi-objective efficiency-vs.-power-density Pareto optimization to include environmental impacts like carbon footprint or damage to ecosystems as further optimization dimensions, considering the entire life cycle including the use phase. Finally, steps towards embedding environmental awareness into the power electronics design process are outlined, targeting full circular economy compatibility of power electronics as a main enabler of the net-zero-CO<sub>2</sub> society.

## Further Reading

- J. Huber, L. Imperiali, D. Menzi, F. Musil, and J. W. Kolar, “Life-cycle carbon footprints of low-voltage motor drives with 600-V GaN or 650-V SiC power transistors,” in *Proc. Int. Conf. Integr. Power Syst. (CIPS)*, Düsseldorf, Germany, Mar. 2024.
- J. Huber, L. Imperiali, D. Menzi, F. Musil, and J. W. Kolar, “Energy efficiency is not enough!,” *IEEE Power Electron. Mag.*, vol. 11, no. 1, pp. 18–31, Mar. 2024.
- L. Imperiali, D. Menzi, J. W. Kolar, and J. Huber, “Multi-objective minimization of life-cycle environmental impacts of three-phase AC-DC converter building blocks,” in *Proc. IEEE Appl. Power Electron. Conf. Expo. (APEC)*, Long Beach, CA, USA, Feb. 2024.
- J. W. Kolar, L. Imperiali, D. Menzi, J. Huber, and F. Musil, “Net zero CO<sub>2</sub> by 2050 is NOT Enough (!),” *Keynote at the 25th Europ. Conf. Power Electron. Appl. (EPE)*, Aalborg, Denmark, Sep. 2023.

